

**A Study of the Factors Affecting the Gross Alpha Measurement, and a Radiochemical Analysis of some Groundwater Samples from the State of Wisconsin Exhibiting an Elevated Gross Alpha Activity.**

Michael F. Arndt, Ph.D., Assistant Researcher, Radiochemistry Unit and Inorganic Chemistry Unit, Wisconsin State Laboratory of Hygiene.

Lynn West , Radiochemistry Unit, Wisconsin State Laboratory of Hygiene.

Principal Investigator

William C. Sonzogni, Ph.D.  
Director, Environmental Health (Laboratory of Hygiene)  
Professor, Environmental Chemistry and Technology  
P.O. Box 7996  
Madison, WI 53707-7996  
608/224-6200  
608/224-6267 (FAX)  
Note: For non-US Mail shippers, use  
2601 Agriculture Drive  
Madison, WI 53718

## Abstract.

Ninety eight groundwater samples from water utilities from around the state of Wisconsin were analyzed for uranium activity (U-234, U-235, and U-238), thorium activity (Th-228, Th-230, Th-232), radium activity (Ra-226 and Ra-228), polonium-210 activity (Po-210), and gross alpha activity. The gross alpha activity was determined using EPA method 900.0. Many of these groundwater sources were known to have a combined Ra-226 and Ra-228 activity in excess of 5 pCi/L, which is a radium violation according to EPA regulations. Most of these samples contained insignificant amounts of thorium or Po-210. The activity of thorium found in the all of the samples was on the order of 0.1 pCi/L or less. Only two samples contained Po-210 at a level of 1 pCi/L or more. A model was developed to determine the contribution of each radionuclide to the gross alpha activity. An analysis of the factors affecting the gross alpha measurement was conducted using this model. The gross alpha activity depends appreciably on the radionuclide used as the calibration standard, the time between sample collection and sample preparation, and the time between sample preparation and sample analysis. The adjusted gross alpha activity, the gross alpha activity minus the total uranium activity, can depend appreciably on whether a radiochemical or a gravimetric method is used to determine the total uranium activity. This is important since according to EPA regulations an adjusted gross alpha activity exceeding 15 pCi/L is considered to be a gross alpha violation. Using the model, it is shown that for some water samples the value obtained for the adjusted gross alpha activity can range from being well within compliance to being well out of compliance as the parameters affecting the gross alpha activity are varied within the limits set forth by Method 900.0. In cases where a water sample was analyzed within a few days of collection, it was found that if the sample contained a significant amount of Ra-228, the measured gross alpha activity was significantly greater than the calculated gross alpha activity unless it was assumed that the sample also contained Ra-224 at a level approximately equal to the Ra-228 activity. This result is not unexpected since Ra-224 is in secular equilibrium with Ra-228. In many cases, the majority of the gross alpha activity of a sample was due to the alpha-emitting progeny of Ra-226 and to Ra-224 and its alpha-emitting progeny. This situation often leads to confusion about the gross alpha activity, since the activities of the progeny of Ra-226 and of Ra-224 and its progeny are never routinely measured in the laboratory. The use of the model developed in this work should be of assistance in helping a water utility with a gross alpha violation determine the reason for the violation, and, therefore, should be helpful in determining how to treat the gross alpha violation.

## 1. Introduction.

Many naturally occurring groundwaters contain measurable amounts of alpha-emitting radionuclides. The levels of some of these radionuclides, like Ra-226 and Ra-228, are regulated because there are groundwaters in which the levels of these radionuclides are sufficiently high to be deemed unsafe. Current United States Environmental Protection Agency (EPA) regulations<sup>1</sup> require that the combined activities of Ra-226 and Ra-228 be less than 5 pCi per liter. A measurement of the gross alpha activity of a water sample is usually performed before the water sample is tested for radium. The gross alpha activity of a water sample is an estimate of the actual alpha activity of the water sample. If the gross alpha activity is greater than 5 pCi/L but less than 15 pCi/L, then an analysis is performed to determine the Ra-226 and Ra-228 activities of the water sample. If the combined activities of the radium isotopes exceeds 5 pCi/L, then the sample has a radium violation. If the gross alpha exceeds 15 pCi/L, then, in addition to the Ra-226 and Ra-228 activities, the total uranium activity is determined. The total uranium activity is subtracted from the gross alpha activity to obtain the adjusted gross alpha activity. If the adjusted gross alpha activity exceeds 15 pCi/L, then the water sample has a gross alpha violation, even if there is no radium violation.

There are two types of methods available for the measuring the gross alpha activities of water samples: evaporative methods and precipitation methods. An example of an approved evaporative method is EPA Method 900.0.<sup>2</sup> In this method a water sample is evaporated, and the solid residue containing the radionuclides is analyzed for alpha activity. An example of a precipitation method is EPA Method 900.1.<sup>3</sup> In this method the radium isotopes are co-precipitated with barium sulfate, and the precipitate is analyzed for alpha activity. In general, an evaporative method is less costly and less time consuming to perform than a precipitation method. For this reason EPA Method 900.0 is the method used at the Wisconsin State Laboratory of Hygiene and many other laboratories. Thus, EPA Method 900.0 is analyzed in detail in this work, although the general principles involved would apply to any of the methods.

In EPA method 900.0, a water sample for gross alpha activity analysis is prepared using a small volume of water, typically 200 mL or less. Nitric acid is added to the sample and the sample is evaporated to near dryness. This step is repeated. The purpose of adding the nitric acid is to reduce the chloride content of the sample, thereby making the sample less corrosive to the stainless steel planchet in the next step. The sample is transferred to the planchet and is reduced to dryness. Then the resulting solid film in the planchet is heated to redness using a Meeker burner. The purpose of this step is to convert the nitrates in the film to oxides, and to reduce the mass of the film. The nonvolatile radionuclides that were originally in the water sample are now contained in the solid film of the planchet. Since radon is volatile, immediately after sample preparation, the solid film contains only a small fraction of the radon activity present in the original sample. The emission rate of alpha particles from the solid film is measured using a gas proportional counter. Then the gross alpha activity is calculated using the alpha-particle emission rate, the mass of the solid film, and an experimentally determined calibration curve.

The interpretation of the gross alpha measurement has been a source of much confusion among water utility operators and workers in the environmental and public health fields. As mentioned above, the gross alpha activity is an estimate of the actual alpha activity of a water sample (excluding radon, which was lost during the evaporation and heating processes). As will be seen below, the gross alpha activity is often a substantial overestimate of the actual alpha activity of the nonvolatile radionuclides of the water sample. Many think that the sum of the total uranium activity and the Ra-226 activity should equal the gross alpha activity. In general, this is not the case. Many other factors affect the gross alpha measurement. On the time scale of a typical gross-alpha measurement, Ra-226 decays into a series of alpha emitters that contribute to the gross alpha activity. Also, although Ra-228 is a beta emitter, the presence of Ra-228 in a water sample indicates the presence of its decay product Ra-224. The activity of Ra-224 in water samples is never routinely determined. Like Ra-226, Ra-224 decays into a series of alpha emitters that contribute to the gross alpha activity. Many other factors affect the gross alpha activity like the alpha-particle energy of a particular radionuclide; the radionuclide that is used as the calibration standard (natural uranium or Th-230); the uniformity of the film in the planchet; the time between sample collection and sample preparation; and the time between sample preparation and the gross-alpha measurement.

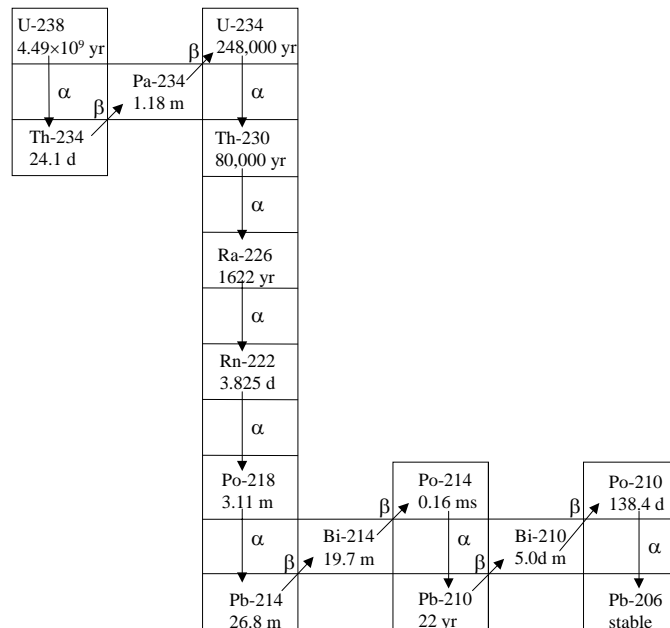
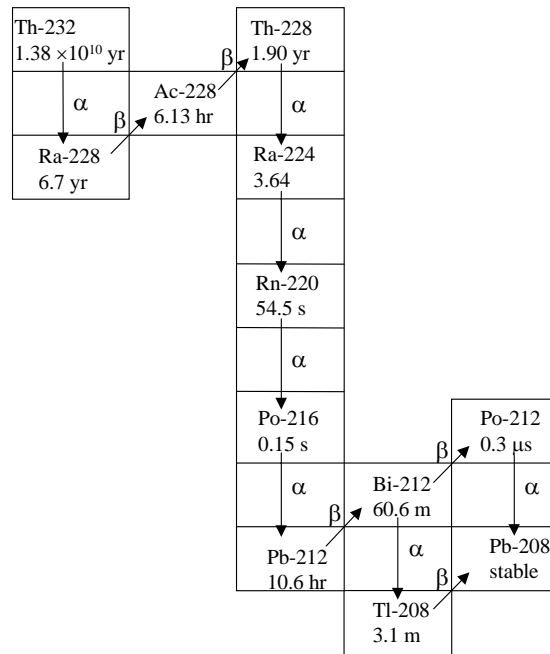

**Figure 1.** U-238 decay scheme.

The state of Wisconsin is known to have many public waterworks using groundwater in which the groundwater is known to be in violation of the current radiological standards. Consequently, these groundwaters provide a good source of samples for the current gross alpha study. Ninety eight groundwater samples from around the state of Wisconsin were collected, mostly from water supplies in which there were known radium or gross alpha

violations. A series of radiological tests were performed on these samples including a gross alpha analysis and analyses for the following radionuclides: Po-210, Rn-222, Ra-226, Ra-228, Th-228, Th-230, Th-232, U-234, U-235, and U-238. The purpose of this report is to quantify the effect of the various physical and radiological factors on the gross alpha activity measurement.

The main natural alpha emitters found in raw water samples are members of either the U-238, the U-235, or the Th-232 decay series. In radiological terms, the abundance of radionuclides belonging to the U-235 decay series is much less than the abundance of radionuclides belonging to either the U-238 or the Th-232 decay series. Consequently, the contribution of U-235 and its progeny to the gross alpha activity will be neglected. The U-238 and Th-232 decay series are shown in Figures 1 and 2, respectively. The presence of a radionuclide in groundwater depends on some complex chemical and geological phenomena. The ultimate source of a U-238 or Th-232 is an ore containing one or both of these radionuclides. Because groundwater often flows at a considerable rate, a radionuclide can be found far from its source. In this report we are not concerned with the ultimate source of a radionuclide, but are concerned with which radionuclides are actually found in the groundwater samples and how these radionuclides contribute to the gross alpha.



**Figure 2.** Th-232 decay scheme.

In general, radionuclides are distributed among various phases. A radionuclide can be part of a parent ore, dissolved in water, adsorbed to the surface of a solid, or part of a solid matrix that was created as matter that was dissolved in solution deposited from

solution. If one accounts for all of the activity of a radionuclide among these various phases, one finds that the activity of the radionuclide is approximately equal to the activity of the parent, either U-238 or Th-232. This phenomenon is known as secular equilibrium. Secular equilibrium occurs when the half-life of the parent nuclide is much longer than the half-life of any of the progeny nuclides. Inspection of Figures 1 and 2 shows that this is the case for both the U-238 and Th-232 decay series. A further example of secular equilibrium for Ra-226 will be given in Section 1.4.

**1.1. Physical and chemical factors affecting the presence of radionuclides in groundwater.** Although secular equilibrium exists in the U-238 and Th-232 decay series, the amount of a particular radionuclide found in water will depend to a large extent on some of the physical and chemical properties of the radionuclides. For example, when a radionuclide undergoes alpha decay, it emits an alpha particle with several million electron-volts of energy. To conserve momentum, the nucleus that emits the alpha particle will recoil in the direction opposite to the direction in which the alpha particle was emitted. If the parent nuclide started in the solid phase, the progeny nucleus may have recoiled far enough for it to have reached the aqueous phase. For example, suppose that in an aquifer U-238 is present in an ore, which may be a small grain of material. When the U-238 decays, the recoiling Th-234 nucleus may reach the aqueous phase and precipitate from solution. The Th-234 atom then undergoes two successive beta decays forming a U-234 atom, which readily goes into the aqueous phase. Without the recoil step, this atom of U-234 would have remained in the parent ore. This process tends to enrich the aqueous phase in U-234 relative to U-238. This phenomenon, known as disequilibrium,<sup>4</sup> can be seen in the U-234 and U-238 activity data collected in this study (see Appendix A).

Chemical properties tend to determine the amount of some of the radionuclides in water. For example, uranium has two common oxidation states, the +4 state and the +6 state. In the +6 oxidation state uranium is in the form of the soluble uranyl ion  $\text{UO}_2^{+2}$ ; in the +4 oxidation state uranium is usually insoluble and precipitates from solution. The oxidation state that uranium is in usually depends on the amount of dissolved oxygen in the water. In water with high levels of dissolved oxygen, the uranyl ion forms and uranium is quite soluble; in anaerobic water, the uranium is reduced to the +4 state, and such waters are usually low in dissolved uranium.

The amount of radium in water is affected by other factors. Radium tends to adsorb onto the surfaces of solids in an aquifer. The amount of radium in the water would be expected to be relatively higher when the number of such adsorption sites is relatively low. In addition, radium competes with other metals— e.g., barium, calcium and magnesium — for these adsorption sites. This is known as the common-ion effect. Consequently, aquifers whose water contains relatively high dissolved solids tend to have correspondingly higher levels of radium.<sup>5</sup>

Thorium exists naturally in the +4 oxidation state only, so it does not participate in any oxidation-reduction reactions. Thorium is soluble in acidic solutions, but thorium hydroxide,  $\text{Th}(\text{OH})_4$ , begins to precipitate from solution at a pH of about 3. The solubility product constant of  $\text{Th}(\text{OH})_4$  is about  $10^{-50}$ , so in near neutral solution, thorium

precipitates almost quantitatively from solution.<sup>6</sup> Very little thorium has been found in any of the groundwater samples tested in this study (see Appendix A).

Polonium is soluble in highly acidic solutions, but is relatively insoluble in neutral solutions. Polonium tends to adsorb onto surfaces. It is sometimes found on colloids suspended in solution. These colloids are sometimes referred to as radiocolloids.<sup>7</sup> Most of the groundwater samples tested in this study had very little Po-210. However, there were two water samples (samples 80732 and 80743 in Appendix A and B) that contained a substantial amount of Po-210. The origin of Po-210 in these two samples is not clear. These samples were not characterized chemically or analyzed for colloidal matter.

Radon gas is relatively soluble in water.<sup>8</sup> It is not unusual for a water sample to contain several thousand pCi of Rn-222 activity. However, such high levels of radon are never observed in samples prepared for a gross alpha-measurement. The reason for this is due to the volatility of radon. During the phases of sample preparation in which the sample is evaporated and in which the solid film is heated with a Meeker burner, most of the radon originally present in the sample is driven off. This does not mean that Rn-222 is not present in the solid film. Rn-222 is continually being produced by the decay of Ra-226, and once the film solidifies, the Rn-222 atoms produced by Ra-226 decay are trapped in the solid film.

None of the water samples were tested for any isotopes of bismuth or lead. From Figures 1 and 2 it is seen that all of the isotopes of bismuth have relatively short half-lives and would be expected to decay away rather quickly. Most of the lead isotopes in these two figures are either stable (at the end of the decay series) or have relatively short half-lives. The exception is Pb-210, which has a half-life of 22 years. Although Pb-210 is not an alpha emitter, it undergoes two successive beta decays to form Po-210, an alpha emitter.

**1.2. Relevant time scale and significance of radionuclide levels.** In this study the water samples were processed for gross alpha activity relatively soon after sample collection, usually within one week. In some cases the sample batch did not meet quality control standards, and were reanalyzed. Consequently, a few samples were reanalyzed one or two months after sample collection. Thus, in the following discussion we will be concerned with radioactive transformations that occur on a time scale of about one month or less.

Many of the most abundant radionuclides found in the water samples in this study occurred at a level of 1 pCi/L or more. Thus, for our purposes an activity on the order of 1 pCi/L will be assumed to be substantial, and an activity on the order of one-tenth of a pCi/L or less will be assumed to be negligible.

**1.3. Supported and unsupported activity.** In general, to account for the alpha activity in a water sample, one must know the activities of all of the radionuclides that are present in the sample, and one must determine how the activities of these radionuclides change with time. Before going into greater detail, some definitions are in order. With the exception of the radionuclides at the beginning and end of each series, a radionuclide is both being produced by the decay of its parent and being consumed by its own decay into its progeny. Conceptually, the activity of any radionuclide can be divided into two categories: supported activity and unsupported activity. The activity of a radionuclide in a water sample is unsupported if the radionuclide has no parent, or if the parent is not

present in the sample and is not being produced by decay processes in significant amounts over the time scale of interest. Thus, the activity of an unsupported radionuclide will decay away with its characteristic half-life. Examples of radionuclides that are unsupported are U-238 and Th-232. Since these radionuclides are at the beginning of their respective decay series, they cannot be produced, and, therefore, all of their activity is unsupported. Another example of unsupported activity is that of Ra-226. Th-230, the parent of Ra-226, is highly insoluble in water, and was not present in significant amounts in any of the water samples in this study. It is possible that U-234 could decay to Th-230 and then to Ra-226, but on a time scale of one month, the amount of Ra-226 produced by this process is negligible. Thus, for the present purposes, the activity of Ra-226 is unsupported.

At the other extreme are radionuclides whose activities are completely supported. The activity of a radionuclide is completely supported if the existence of its activity is due only to the decay of its parent. In the solid film the Rn-222 activity is completely supported by the decay of Ra-226. As discussed in Section 1.1, Rn-222 is driven off of the solid film during the evaporation and heating processes. After the heating step, as time progresses, Rn-222 is produced by the decay of Ra-226. Consequently, the existence of Rn-222 activity in the sample is completely due to the decay of its parent, Ra-226.

There can be cases of an intermediate nature, where the activity of a radionuclide is neither completely supported nor completely unsupported. That is, a water sample may contain a radionuclide and its parent, but the activity of the radionuclide may be in excess of what the decay of the parent in the water sample could have produced. In such cases, for accounting purposes, the activity of the radionuclide can be arbitrarily divided into supported and unsupported activity. One may classify the original activity of the radionuclide in the water sample as unsupported and classify the activity that arises due to the parent decay as supported. The unsupported activity of the radionuclide will decline with a time constant that is characteristic of the half-life of the radionuclide. Simultaneously, the supported activity, which is initially zero, will increase as the parent decays, possibly going through a maximum and then decreasing as the parent decays away.

In the case of the U-238 and Th-232 decay series there are numerous considerations that allow us to focus on subsections of these decay series, rather than considering the decay series as a whole. These subsections consist either of a single radionuclide or of a sequence of radionuclides, the first member of which supports the activities of the subsequent members. This is the subject of the next two sections.

**1.4. Subsections of the U-238 decay series.** The activity of U-238 is assumed to be constant, since its activity is unsupported and its lifetime is 4.49 billion years. Before defining other subsections, it is helpful to use U-238 as an example to estimate how the activity of a parent affects the activities of its progeny. In general, to determine the effect that the decay of a parent radionuclide will have on the activities of its progeny, one must solve of system of coupled differential equations. However, for the radionuclides at the beginning of the U-238 decay series, some approximate calculations are sufficient.



It should be noted that the lifetimes of the radionuclides in each series range over many orders of magnitude. For example, in the U-238 series, the half-life of U-238 is 4.49 billion years, whereas the half-life of Po-214 is 0.16 ms. This is a range over almost 21 orders of magnitude. The activity,  $A$ , of a given radionuclide is given by

$$A = \frac{\ln(2)}{t_{1/2}} N, \quad (1)$$

where  $t_{1/2}$  is the half-life of the radionuclide and  $N$  is the number of atoms of the radionuclide. This formula has been used to obtain the results in Table 1.<sup>9</sup> In this table for a selection of radionuclides, the half-life is given in seconds, and the corresponding number of atoms required to produce 1 pCi of activity is given. Again, it is seen that the number of atoms required to produce 1 pCi of activity ranges over almost 21 orders of magnitude.

**Table 1.** Number of atoms required to produce 1 pCi of activity.

Nuclide	Half-life (s)	No. atoms to produce 1 pCi.
U-238	$1.42 \times 10^{17}$	$7.56 \times 10^{15}$
Th-234	$2.08 \times 10^6$	$1.11 \times 10^5$
Pa-234	70.8	3.78
U-234	$7.80 \times 10^{12}$	$4.17 \times 10^{11}$
Th-230	$2.52 \times 10^{12}$	$1.35 \times 10^{11}$
Ra-226	$5.112 \times 10^{10}$	$2.73 \times 10^9$
Rn-222	330,000	17600
Po-214	$1.6 \times 10^{-4}$	$8.54 \times 10^{-6}$
Pb-210	$6.94 \times 10^8$	$3.71 \times 10^7$
Bi-210	432,000	23,000
Po-210	12,000,000	638,000

One pCi of activity is about 0.037 decays per second, or about 1 decay every 27 seconds. Thus, a decay rate of 1 pCi corresponds to about 96,000 disintegrations in 30 days. In one month, 1 pCi of U-238 will undergo about 96,000 disintegrations and produce 96,000 atoms of Th-234. The addition of 96,000 atoms to either of the beta emitters Th-234 or Pa-234 will be substantial, but the addition of 96,000 atoms to 1 pCi of the alpha-emitter U-234 only amounts to about  $2.3 \times 10^{-5}$  % of the U-234 atoms. Consequently, on a time scale of about one month, an activity of 1 pCi of either U-238, or Th-234, or Pa-234 will have virtually no effect on the U-234 activity. And because U-234 has a half-life of 248,000 years, its activity can be assumed to be constant.

The next subsection in the U-238 series starts with Ra-226. The Ra-226 activity is unsupported because its parent, Th-230, is highly insoluble, so that the activity of Th-230 in the water samples amounts, at most, to a few tenths of a pCi. The decay of 0.1 pCi of Th-230 in one month produces about 9,600 Ra-226 atoms, which is about  $3.5 \times 10^{-4}$  % of the Ra-226 atoms in 1 pCi of Ra-226. One might be concerned with the amount of Ra-226 that is produced indirectly by the decay of U-234. If a sample contains 1 pCi of U-

234, then 96,000 atoms of its progeny, Th-230, would be produced in 30 days. From Equation (1) the activity of 96,000 atoms of Th-230, the parent of Ra-226, is only 0.83 decays per year. Consequently, on a time scale of one month, the Ra-226 activity can be assumed to be unsupported.

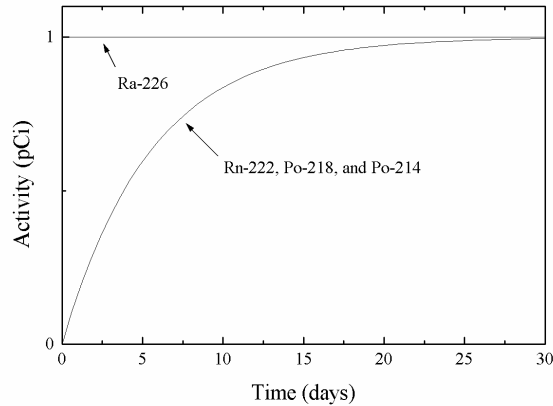

**Figure 3.** Ra-226 and progeny.

From Figure 1, it is seen that the five radionuclides—Rn-222, Po-218, Pb-214, Bi-214 and Po214— following Ra-226 have relatively short half-lives as compared to Ra-226 (on the order of milliseconds to a few days). If these progeny were unsupported, their activities would tend to decay away rather quickly. However, these progeny are supported by the decay of Ra-226, and it is clear that the decay of Ra-226 over a period of days will have a substantial effect on the activities of these progeny. Three of the progeny are alpha-emitters—Rn-222, Po-218, Po214—and their activities must be determined in order to account for the gross alpha activity results. Such a calculation is readily performed using the Bateman equations. The Bateman equations are the solutions of a series of coupled linear differential equations governing the decay of a series of radionuclides. Figure 3 shows the result of a calculation in which the activity of the three alpha-emitting progeny (Rn-222, Po-218, and Po-214) of Ra-226 are determined as a function of time. On the time scale in the figure the activities of Rn-222, Po-218, and Po-214 are virtually equal.

The plot in Figure 3 demonstrates a phenomenon known as secular equilibrium. If the half-life of the parent radionuclide, Ra-226, is much longer than the time scale of interest, (30 days), then the activity of the parent will be virtually constant over the time scales of interest. If the half-lives of the progeny (Rn-222, Po-218, Pb-214, Bi-214, and Po-214) are short compared to the time scale of interest (30 days), then the activities of the progeny will closely approach the activity of the parent over the duration of the time scale of interest. The reason for this is relatively simple. Each of the progeny is being produced by the decay of its immediate parent and is being consumed by its own decay. The decay of a radionuclide is a first order process. In a first order process, the probability per unit time,  $\lambda$ , that an atom will decay is independent of the presence of other atoms. In a population of atoms, all of the atoms have the same probability of decaying, so that if there a  $N$  atoms in the population, then the instantaneous rate of decay

of atoms is just  $\lambda N$ . Thus, if the population of a particular radionuclide is doubled, then the decay rate of that population is doubled. Initially, the number of Rn-222 atoms is zero, but as Ra-226 decays, Rn-222 atoms are being created at a constant rate, which is just the decay rate of Ra-226. Some of these Rn-222 atoms decay, but, initially, they tend to accumulate. As the Rn-222 atoms accumulate, their decay rate increases (remember more atoms lead to a higher decay rate). The Rn-222 population increases until the Rn-222 decay rate equals the rate at which Rn-222 is produced, which is equal to the decay rate of Ra-226. At this point, the population of Rn-222 has stabilized. Now the stable population of Rn-222 atoms is producing Po-218 atoms at a constant rate (the decay rate of Ra-226), and the Po-218 population will build until the decay rate of Po-218 equals its rate of production (the decay rate of Ra-226). The process of building radionuclide populations whose activities equal the activity of Ra-226 will keep occurring for each radionuclide along the decay series, as long as the Ra-226 half-life is long compared to the half-life of the radionuclide of interest, and as long as the half-life of the radionuclide is short compared to the time scale of interest. Further down the decay series Pb-210 is encountered with a 22 year half-life. On our time scale of interest (30 days), 22 years is a long time, and the Pb-210 population will not have built to a large enough number and have stabilized such that the decay rate of Pb-210 equals the decay rate of Ra-226. The next alpha-emitting radionuclide after Po-214 is Po-210. If one uses the Bateman equations to determine the activity of Po-210 produced from Ra-226, one finds that it takes approximately 1440 days to produce 0.1 pCi of Po-210 from 1 pCi of Ra-226. The low production of Po-210 from Ra-226 is due to the relatively long half-life of Pb-210 (22 years). On a one-month time scale the Pb-210 population arising from the decay of Ra-226 gives rise to a negligible Pb-210 activity. In effect, on a one-month time scale the presence of Pb-210 in the decay chain acts as a “bottleneck” for the production of Po-210 from Ra-226.

Actually, in Figure 3 it is seen that the activities of Rn-222, Po-218, and Po-214 are virtually the same. This is because the half-lives of the progeny Po-218, Pb-214, Bi-214, and Po-214 are much less than the half-life of Rn-222. Consequently, these progeny species come into secular equilibrium with Rn-222 rather quickly on the time scale in Figure 3.

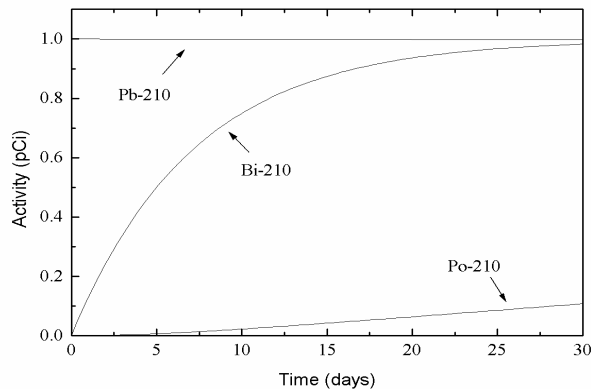

**Figure 4.** Pb-210 decay and Po-210 ingrowth.

As mentioned above the activity of Pb-210 was not determined in the samples. The amount of Pb-210 present in the water samples is of interest because it decays into the alpha-emitting Po-210. Figure 4 is a plot of the ingrowth of Bi-210 and Po-210 from 1 pCi of Pb-210 over a period of 30 days. After 30 days, Bi-210 is in secular equilibrium with Pb-210, but the activity of Po-210 produced is about 0.1 pCi. When one measures the activity of Po-210 in a sample, because of its relatively short half-life (134 days), one decay corrects the Po-210 activity to obtain the Po-210 activity in the sample at the time of collection. If 0.1 pCi is decay corrected backward 30 days, it is found that it results in an initial Po-210 activity of 0.12 pCi. Consequently, for the present purposes, it likely not necessary to measure the activity of Pb-210.

Another source of Po-210 is Bi-210. If 1 pCi of Bi-210 completely decays, then, from the data in Table 1, it is clear that this would amount to about 3.6 percent of the number of Po-210 atoms in 1 pCi of Po-210 activity. For the present purposes, this is insignificant.

To summarize, in considering the U-238 decay series, we need to consider only U-238; U-234; Ra-226 and its subsequent three alpha-emitting progeny (Rn-222 Po-218, and Po-214); and Po-210.

**1.5. Subsections of the Th-232 decay series.** The data in Appendix A show that the activities of Th-232 and Th-228 in all of the groundwater samples were insignificant. This is presumably due, in part, to the formation of insoluble  $\text{Th}(\text{OH})_4$ . The activity of Ra-228 is of interest because its presence in a water sample is a certain indicator of the presence of Ra-224 in the water sample. In this project, the Ra-228 activity was measured, but not the Ra-224 activity. It is not difficult to show that, on a one-month time scale, the activities of the radionuclides preceding Ra-224 in the Th-232 decay series have a minor effect on the activity of Ra-224. As mentioned above, the thorium isotopes are not important because of their insolubility. The decay of Ra-228 and Ac-228 will not significantly alter the activity of Ra-224 because Th-228 has a half-life of 1.9 years. This is seen in the plot in Figure 5 where the ingrowth of Ra-224 from 1 pCi of Ra-228 is plotted. Thus, Th-228 acts as a “bottleneck” for the production of Ra-224, in the same way that Pb-210 acts as a “bottleneck” for the production of Po-210 from Ra-226. Although the presence of Th-228 limits the amount of Ra-224 produced over a one-month time scale, Figure 5 shows that there is significant ingrowth of Ra-224 from Ra-228 over a period of a few years, and, consequently, the presence of Ra-224 in aquifers containing high levels of Ra-228 should be expected. In fact, Ra-224 is in secular equilibrium with Ra-228. Moreover, because Th-228, an alpha emitter, is between Ra-228 and Ra-224 in the decay series, some water samples may actually be enriched in Ra-224 relative to Ra-228.<sup>10</sup>

The above considerations show that, in the Th-232 decay series, one only has to be concerned with the activity of Ra-224 and its progeny. From Figure 2 it is seen that all of the progeny of Ra-224 have relatively short half-lives. Thus, unless they are supported by Ra-224 decay, their activities would quickly decay away. Four of the Ra-224 progeny—Rn-220, Po-216, Bi-212, and Po-212—are alpha emitters, and their activities must be calculated in order to account for their effect on the gross alpha activity. Since the activity of Ra-224 was not determined, the Ra-224 activity will be estimated using the calculations outlined below. In general, the results of the calculations will show that the

ratio of the activity of Ra-224 to the activity of Ra-228 ranges from 1 to 2, which is in agreement with previous studies.<sup>11</sup>

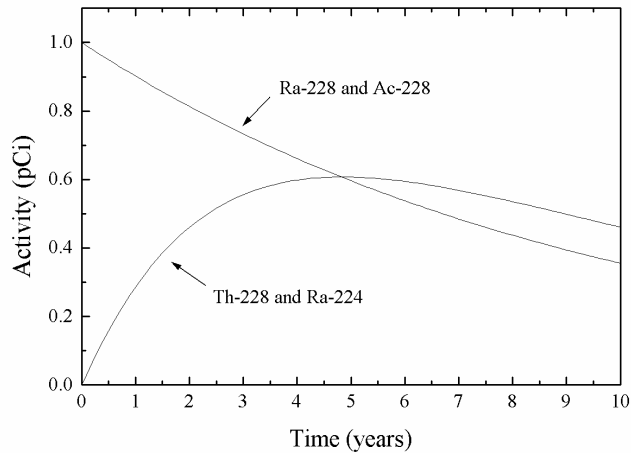

**Figure 5.** Ingrowth of Ra-224 .

From the discussion in the previous two sections, we know which radionuclides in our water samples will be important contributors to the gross alpha activity (U-238; U-234; Ra-226 and its subsequent three alpha-emitting progeny; Po-210; and Ra-224; and its four subsequent alpha-emitting progeny). The activities of U-238, U-234, and Ra-226 have been measured. The activity of Ra-224 can be estimated from the model discussed in Section 2. The activities of the alpha-emitting progeny of Ra-226 and Ra-224, although not measured, can be readily calculated using the Bateman equations.

**1.6. Methods of Analysis.** The gross alpha activities of the groundwater samples were determined using EPA Method 900.0<sup>2</sup> employing Th-230 as the calibration standard. Method 900.0 stipulates that the time between sample preparation and analysis should be three days or more, to allow for the ingrowth of the progeny of Ra-226. However, in this work the samples were analyzed as soon as possible after preparation in order that the contribution of the short-lived Ra-224 and Ra-224 progeny would be detected.

The Ra-226 and Ra-288 activities were determined using EPA Methods 903.1<sup>12</sup> and 904.0,<sup>13</sup> respectively. The Po-210 activity was determined using a modified version of Procedure Po-02-RC, the Environmental Measurements Laboratory, United States Department of Energy.<sup>14</sup> It was found that during volume reduction of the acidified sample by evaporation, silica gel formed from silicic acid present in the sample. This reaction is catalyzed by acids,<sup>15,16</sup> which are concentrated during the evaporation of the sample. To prevent the formation of silica gel, the acidified water samples were digested with hydrofluoric acid. A water sample was reduced in volume to about 200 mL, and transferred to a 400-mL Teflon beaker. Then 10 mL of 48% hydrofluoric acid was added to the beaker, and the contents of the beaker were evaporated to dryness. An acidic boric acid solution was added to the beaker, which dissolved the sample and reacted with any fluoride ion that was left. In Procedure Po-02-RC the sample is reduced in volume to 5 mL, not to dryness, and the polonium is co-precipitated with lead sulfide. However, in

this step, when the pH of the solution was adjusted to bring about the precipitation of lead sulfide, a large amount of another precipitate formed, which was probably one or more metal hydroxides. Consequently, the co-precipitation step was omitted. The acidic boric acid solution usually contained a small amount of insoluble white matter, so the solution was filtered, and the polonium in the filtered solution was deposited on a nickel disc, as in the original procedure.

The activities of the uranium isotopes were determined using alpha spectroscopy. The samples were prepared for analysis using Eichrom Method ACW02<sup>17</sup> employing U-232 as the tracer. The activities of the thorium isotopes were determined using alpha spectroscopy. The samples were prepared using a modified version of Eichrom Method ACW10<sup>18</sup> employing Th-229 as the tracer. Initially, when Eichrom Method ACW10 was employed, the yield of the thorium tracer was low and somewhat variable. The cause of the low yields was traced to two steps in the procedure. First, there is a co-precipitation step in the procedure in which thorium purportedly co-precipitates with a calcium phosphate precipitate, which is formed when the acidic solution is made slightly basic. It was evident that the percentage of thorium that co-precipitated was usually quite low and variable. Experiments showed that the addition of magnesium to the solution before the co-precipitation step was performed greatly increased the amount of thorium in the precipitate. A molar ratio of magnesium to calcium of 5:1 was optimal. For practical purposes, since the amount of calcium in each sample was unknown, an amount of magnesium was added to the solution to assure that the magnesium to calcium ratio was 5:1 or greater. Also, adding sodium carbonate to the solution was found to increase the thorium yield in the precipitate. Thus, when the acidic solution was at or near neutral pH, just before precipitation occurred, about 1 g of sodium carbonate was added to the solution. It was also found that if fluoride was present at a level of about 1 ppm, the amount of thorium in the precipitate was usually low and somewhat variable. Consequently, prior to the co-precipitation step, boric acid was added to the solution, and the solution was heated for an hour so that the boric acid would react with the fluoride.

The second step affecting the Th-229 yield was the micro-precipitation step, in which the thorium was co-precipitated with cerium fluoride. Eichrom Method ACW10 calls for the use of 1 mL of 48% hydrofluoric acid in this step, which results in low Th-229 yields. The use of 5 mL of 48% hydrofluoric acid in this step increases the Th-229 yield to an acceptable level.

## 2. The Model.

**2.1. Introduction.** In the following sections the model used to calculate the gross alpha activities of the water samples is discussed. The use of such a model is important for several reasons. The model gives one a deeper insight into the physical and radiochemical processes that affect the gross alpha activity measurement; a successful model allows one to perform computer experiments, which are usually faster than performing experiments in the laboratory; and one can obtain results from the model that would be difficult at best to perform in the laboratory. As an example of this last point, many of the supported short-lived progeny of Ra-224 and Ra-226 have very high alpha-particle energies as compared to the alpha-particle energies of their parents. Consequently, the contribution

of one of the progeny to the gross alpha activity can be significantly greater than the contribution of its parent. It would be virtually impossible to isolate one of these progeny because of its short half-life and because it decays into other radioactive progeny relatively quickly. Thus, experimentally, it would be difficult to isolate the effect of one of these progeny on the gross alpha activity. However, using a model, the contribution of one of these short-lived progeny on the gross alpha activity can be readily determined. The discussion of the model will start with a discussion of the composition of the solid film in the planchet.

**2.2. Solid film composition.** Table 2 gives the average composition of a groundwater sample from a sandstone aquifer.<sup>19</sup> As discussed in the introduction, the chloride content of a water sample is reduced by alternately adding nitric acid to the sample and evaporating. Presumably, the bulk of the residue left in the planchet after this procedure is performed is a mixture of metal nitrates and sulfates [ $\text{NaNO}_3$ ,  $\text{Na}_2\text{SO}_4$ ,  $\text{KNO}_3$ ,  $\text{K}_2\text{SO}_4$ ,  $\text{Mg}(\text{NO}_3)_2$ ,  $\text{MgSO}_4$ ,  $\text{Ca}(\text{NO}_3)_2$ ,  $\text{CaSO}_4$ ,] and some silicic acid ( $\text{SiO}_4$ ). Since silicic acid decomposes at 150 C, it will be assumed that any dissolved  $\text{SiO}_4$  decomposes to amorphous  $\text{SiO}_2$  upon heating. In general, the sulfate salts do not melt or decompose below 800 C, so it will be assumed that any sulfate salts present in the solid film are not altered by the heating process. An experiment was performed to determine the stability of nitrate salts during the heating process. When  $\text{Mg}(\text{NO}_3)_2$  or  $\text{Ca}(\text{NO}_3)_2$  is placed in a planchet and heated, it is observed that a brown gas is evolved, probably  $\text{NO}_2$ , and that the mass of the residue left in the planchet is consistent with the formation of the decomposition products  $\text{MgO}$  or  $\text{CaO}$ , respectively. When  $\text{NaNO}_3$  or  $\text{KNO}_3$  is heated in a planchet, the solid melts, but no brown gas is evolved, and the mass of the residue does not change indicating that neither  $\text{NaNO}_3$  nor  $\text{KNO}_3$  decompose.

**Table 2.** Average composition of groundwater.

Element	Concentration (ppm)
Na	$10^{-3.3}$
K	$10^{-4}$
Ca	$10^{-3}$
Mg	$10^{-3.5}$
$\text{H}_4\text{SiO}_4$	$10^{-3.9}$
$\text{SO}_4$	$10^{-3.2}$

In this work it is assumed that the film in the planchet after the heating step is performed is composed of  $\text{NaNO}_3$ ,  $\text{KNO}_3$ ,  $\text{MgO}$ ,  $\text{CaO}$ ,  $\text{MgSO}_4$ ,  $\text{CaSO}_4$ , and  $\text{SiO}_2$ . However, some work must still be done to characterize the decomposition products for mixtures of salts. It is quite possible that, during the heating step, much of the sulfate becomes associated with sodium and potassium, and that most of the nitrate is associated with magnesium and calcium. If this is the case, then, after the heating process, the amount of nitrate salts left in the solid film may be negligible.

**2.3. Energy and efficiency considerations.** Before discussing the model in more detail, it is instructive to discuss qualitatively how the energy of an alpha particle affects the

gross alpha activity. When an alpha-emitting radionuclide decays, it emits an alpha particle at one or more characteristic energies. A schematic diagram of the sample and detection system is given in Figure 6. As discussed in Section 1.1, the radionuclides of a water sample, excluding radon, are contained in the solid film of the planchet. When an alpha-emitting atom of the film decays, it emits an alpha particle. The direction in which the alpha particle is emitted is completely random. As the alpha particle moves through matter, it continually loses energy, eventually coming to rest. Two conditions must hold for an alpha particle to cause a pulse in the detector. First, the alpha particle must have enough energy to reach the active region of the detector (P10 gas fills the active region of the detector and is 10% methane and 90% argon) and, once it reaches the active region, it must have enough residual energy to ionize enough molecules of the P10 gas to cause a measurable pulse in the detector. Second, the alpha particle must be emitted in a direction such that it will pass through the active region of the detector.

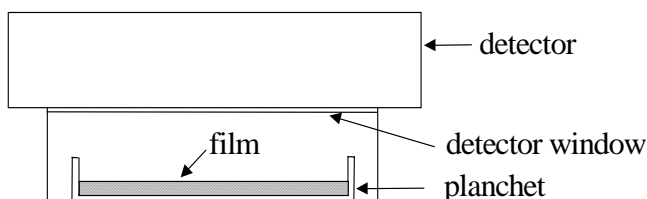

**Figure 6.** Schematic of the sample and detection system.

Alpha particles move in relatively straight lines. Alpha particles lose most of their energy in collisions with electrons. An alpha particle is about 8000 times more massive than an electron, so that a collision with an electron does not cause much of a deviation in the path of the alpha particle. As an alpha particle moves from the solid film to the P10 gas of the detector (traversing the film, about one centimeter of air, and the entrance window of the detector), it continually loses energy. Within a single medium, an alpha particle of a given energy has a relatively well-defined path length. Thus, for a given medium, one can construct plots of the alpha-particle range versus alpha-particle energy. One can then fit a function to these plots to obtain range-energy functions for that medium. The derivation of the range-energy functions for the various media will be discussed in the next section. These plots, or range-energy functions, can be used to determine the amount of energy lost by an alpha particle in traversing a given length of material. Thus, given these range-energy functions, it can be determined whether an alpha particle reaches the P10 gas and whether the alpha particle has enough residual energy to cause a pulse in the detector.

It often happens that an alpha particle loses all of its energy before reaching the detector. It is clear that the more energetic an alpha particle is, the more likely it is that the alpha particle will reach the detector, provided its trajectory has a suitable orientation. An alpha-emitting radionuclide is characterized by the efficiency with which its alpha particles reach the detector. The efficiency of a particular radionuclide is just the ratio of the number of alpha particles reaching the detector and causing a measurable pulse to



the number of alpha particles emitted by the radionuclide in the solid film. It is clear that radionuclides with relatively high alpha-particle energies will have relatively high alpha-particle efficiencies.

**Table 3.** Alpha particle energies for selected radionuclides.

Nuclide	Half-life	Alpha energy (MeV)	Branching ratio
U-238	4.49×10 <sup>9</sup> years	4.147	0.23
U-238		4.196	0.77
U-234	248,000 years	4.7231	0.275
U-234		4.776	0.725
Ra-226	1622 years	4.601	0.055
Ra-226		4.784	0.945
Rn-222	3.825 days	5.4897	1
Po-218	3.11 minutes	5.181	1
Po-214	0.163 ms	7.686	1
Ra-224	3.64 days	5.449	0.05
Ra-224		5.685	0.95
Rn-220	54.5 s	6.2883	1
Po-216	0.15 s	6.778	1
Bi-212	60.6 minutes	6.051	0.723
Bi-212		6.09	0.277
Po-212	0.3 μs	8.784	1
Po-210	138.4 days	5.305	1
Am-241	458 years	5.486	0.860
		5.443	0.127
Th-230	80,000 years	4.684	0.760
		4.617	0.240

In general, alpha particles from short-lived radionuclides are more energetic than alpha particles from longer-lived radionuclides. Table 3 shows the alpha-particle energies for a selection of alpha-emitters.<sup>20</sup> In the event that there are two energies, the branching ratio indicates the fraction of alpha particles emitted at that energy. The last two radionuclides in the table are or have been used to calibrate the detection system. Currently, natural uranium and Th-230 are the only two calibration standards that can be used in EPA Method 900.0. Prior to 1995 Am-241 was allowed to be used as a calibration standard in Method 900.0. As will be discussed in Section 2.8, the gross alpha method implicitly assumes that all of the radionuclides have the same efficiency as the calibration standard. As will be seen in Sections 3.3 and 3.6, the effect of this assumption is that the gross alpha activity of a water sample often greatly exceeds the actual alpha activity of the water sample (excluding radon).

Inspection of the entries in Table 3, reveals that, qualitatively, there is an inverse relationship between the half-life of a radionuclide and the energy of the alpha particle that it emits. The shortest lived but highest energy alpha particles come from the progeny of Ra-224 and Ra-226. Because of their short half-lives, the activities of these progeny are never routinely measured; but because of the high energy of their alpha particles,

these short-lived progeny sometimes account for the bulk of the gross alpha activity. The calculations presented in Sections 3.3 and 3.6 demonstrate this phenomenon.

**2.4. Range-energy functions.** To determine whether an alpha particle of a given energy causes a measurable pulse in the detector, one must know how much energy the alpha particle loses before it enters the active region of the detector (the cylindrical space filled with P10 gas), and how much energy it dissipates in the active region of the detector. To determine how much energy the alpha particle loses on its way to the active region of the detector, one must determine the alpha-particle range-energy functions for the various materials—the solid film, the air layer, and the entrance window of the detector—that the alpha particle traverses on its way to the detector. To determine how much energy is dissipated in the active region of the detector, one must determine the range-energy function of an alpha particle in the P10 gas. The range-energy data for many materials can be obtained using the National Institute of Standards and Technology ASTAR program.<sup>21</sup> The range-energy plot for air is shown in Figure 7. The entrance window is a thin three-layer sheet composed of a thin polyester film with a thin film of aluminum evaporated on either side. The NIST web site has the range-energy functions for aluminum and Mylar, a polyester that will be used to model the polyester film of the window.

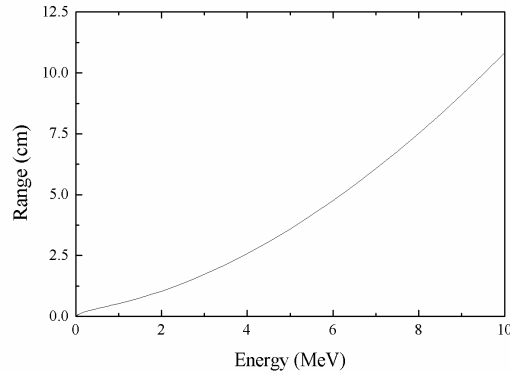

**Figure 7.** Range-Energy Plot for Air.

The composition of the solid film in the planchet is quite complex. The NIST database contains the range-energy relationship for oxygen, but not for any other element of the solid film. The range-energy function for any other element of the solid film can be estimated using the range-energy function of an element whose atomic weight is close to the atomic weight of the element of interest. This is done using the Bragg-Kleeman rule:

$$\frac{R_1}{R_0} = \frac{\rho_0 \sqrt{A_1}}{\rho_1 \sqrt{A_0}}.$$

Here  $R_0$ ,  $\rho_0$ , and  $A_0$  are, respectively, the range, the density, and the atomic weight of the known element; and  $R_1$ ,  $\rho_1$ , and  $A_1$  are, respectively, the range, the density, and the atomic weight of the element whose range is to be estimated. A range-energy function for each element of the solid film was estimated using one element whose atomic weight is

greater than the element of interest and one element whose atomic weight is less than the element of interest. The two estimates were averaged to arrive at the range-energy function for the element.

Once the range-energy functions for each of the constituent elements of the solid film were determined, the range  $R$  of an alpha particle in the solid film could be determined using another formula also called the Bragg-Kleeman rule:

$$R = \frac{1}{\sum_i x_i (A_i / R_i)}$$

Here  $x_i$ ,  $A_i$  and  $R_i$  are the mole fraction, the atomic weight, and the range of the  $i$ th element in the solid film, respectively.

**2.5. The detector.** Initial attempts to model the detector resulted in calculated Th-230 efficiencies that far exceeded the experimentally determined Th-230 efficiencies. It became evident that not every alpha particle reaching the P10 gas caused a measurable pulse. A pulse is generated when electrons created by the ionization of P10 gas molecules are collected at the anode wires of the detector. In order to be counted, a pulse must exceed the discriminator level of the instrument. It may be that the residual energy of the alpha particle is so low that the number of electrons created by the ionization of the P10 gas is too small to generate a pulse that exceeds the discriminator level. However, attempts to model the detector by adjusting the discriminator level upward resulted in discriminator levels that were unreasonable high (they discriminated out pulses of 1 MeV or even more) and resulted in calculations that could not model the efficiencies of several radionuclides simultaneously. It was clear that another phenomenon was at work.

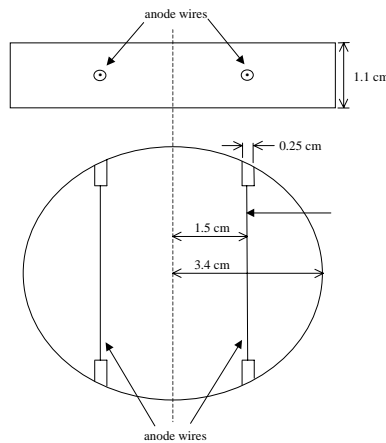

**Figure 8.** Schematic diagram of the detector.

To understand the reason for the lower efficiencies, one must understand the physics of the electron dynamics in the detector. A schematic diagram of the detector is given in Figure 8. The active region of a detector is a cylindrical region filled with P10 gas, a mixture of 10% methane and 90% argon. One face of the cylinder is covered with a thin

entrance window, which allows alpha particles to enter the active region. In the Berthold detection system, there are two wire anodes that traverse the active region. A potential of 1750 V is applied between the anodes and the detector housing. One must remember that an alpha particle ionizes molecules in the P10 gas leaving a trail of electrons and positively charged gas ions. Part of the reason for the potential applied to the anodes is to create an electric field inside the detector that separates the positively charged ions from the electrons before they can recombine. If recombination occurs, then a part of the signal is lost. Because of the design of the detector, there are regions within the detector where the electric field is relatively low and where recombination of ions and electrons is more likely to occur. In order to determine the portions of the detector where the electric field is low, and where recombination is most likely to occur, the electric field in the detector was determined numerically. This was done using a standard finite-difference method known as the Gauss-Seidel method with over-relaxation.

The problem can be simplified somewhat because the active region of the detector has three symmetry planes, each of which divides the detector in half. Taken together the three planes divide the detector into octants. If one obtains a solution in any one of the octants, the solution in any of the other seven octants is easily obtained by reflection of the solution through the symmetry planes. The solution of the finite-difference equations in one of the octants requires three types of boundary conditions. The first boundary condition is that the electrostatic potential must be zero at the boundary of the active region of the detector. The second boundary condition is that the electrostatic potential must be 1750 V at the surfaces of the anode wires. The third boundary condition is that on any of the symmetry planes the component of the electric field normal to the plane must vanish. In other words, the electric field vector on any of the symmetry planes must lie in the plane. If the normal component did not vanish, the solution of the electrostatic field at the symmetry plane would not be unique.

To implement the solution of the finite-difference equations, a Cartesian coordinate system was set up in the detector, and a rectangular array of points was defined inside the detector. Then, using the Gauss-Seidel method with the appropriate boundary conditions, the electrostatic potential was determined at all of the points of this array. Once the electrostatic potential  $\phi$  was determined, the electric field  $\mathbf{E}$  was determined from  $\phi$  by differentiation; i.e.,

$$\mathbf{E} = -\frac{\partial\phi}{\partial x}n_1 - \frac{\partial\phi}{\partial y}n_2 - \frac{\partial\phi}{\partial z}n_3,$$

where  $n_1$ ,  $n_2$ , and  $n_3$  are unit vectors in the  $x$ -,  $y$ -, and  $z$ -directions, respectively. Actually, we are only interested in the magnitude of the electric field  $|\mathbf{E}|$  and not its direction. The magnitude of the electric field is given by

$$|\mathbf{E}| = \sqrt{\left(\frac{\partial\phi}{\partial x}\right)^2 + \left(\frac{\partial\phi}{\partial y}\right)^2 + \left(\frac{\partial\phi}{\partial z}\right)^2}.$$

In the calculations of the radionuclide efficiencies, it was assumed that the detector can be divided into two regions. The two regions are separated by a surface defined by the equation  $|\mathbf{E}| = E_c$ , where  $E_c$  is called the cutoff field. In the first region, called the live region,  $|\mathbf{E}|$  exceeds  $E_c$  and it is assumed that all of the electrons generated in this region are collected at the anode; in the second region, called the dead region, all of the electrons are assumed to recombine with ions and not to reach the anode. The surface between the live and dead regions was constructed using Lagrange basis functions between every set of eight data points that make up a rectangular cell in the finite-difference method.

The division of the detector volume into a live and a dead region is, of course, an approximation since some electrons in the dead region will reach the anode, and some of the electrons in the live region will recombine with ions. However, for our purposes, the division of the detector volume into these two regions gives reasonable results. Figure 9 depicts a cross section of the detector that is perpendicular to the anode wires and divides the detector in half. Figure 9 shows the live and the dead regions for a cutoff field of about 150 V/cm.

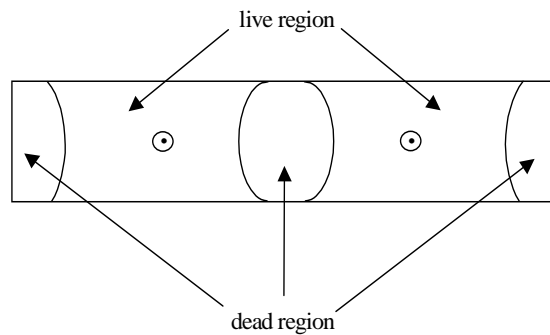

**Figure 9.** Schematic of detector dead and live regions.

From Figure 9 it is clear that there is a significant dead region between the two anodes. This is not unexpected because the three symmetry planes of the detector intersect at the point at the center of the detector. Since the normal component of the electric field vanishes on a symmetry plane, the only way that the normal component of the electric field can vanish on all three planes simultaneously is if the electric field is zero at the center point. There is also a significant dead region at the extremities of the detector. The magnitude of the electric field diminishes at distances far from either anode. In the calculations below, for a pulse to be registered, it is assumed that a certain threshold energy must be deposited in the live region of the detector. An alpha particle may cross from the dead region to the live region, or vice versa, in which case only that portion of the energy deposited in the live region is counted as contributing towards the generation of a pulse.

**2.6. Solid film geometry.** Inspection of a random selection of planchets from processed samples reveals that the solid films are usually not of uniform thickness, but that the

geometry of the films is quite complex. Before a planchet is heated, the film is usually rough, and often not evenly dispersed over the surface of the planchet. When the planchet is heated, the film usually melts and often solidifies into a fairly thick patch, surrounded by a relatively thin film of material. The formation of the thick patch may be due to the surface tension of the melt, which tends to gather the melt together. The presence of these thick patches has a significant effect on the efficiencies of the radionuclides. For a given alpha-particle energy there is a maximum depth,  $z_{\max}$ , within the solid film from which an alpha particle can be emitted and still cause a pulse in the detector. Alpha particles emitted from depths greater than  $z_{\max}$  may reach the detector, but will not have enough energy to cause a pulse in the detector. For films of relatively low mass, if the film is uniform, the film thickness may be less than  $z_{\max}$  for many of the radionuclides. In this case, alpha particles emitted from throughout the entire film can cause a pulse in the detector. However, when a thick patch exists, there are regions of the patch where alpha particles have no chance of causing a pulse in the detector because the thickness of the patch greatly exceeds  $z_{\max}$  for many or all of the radionuclides. Consequently, the presence of these thick patches diminishes the radionuclide efficiency. In order to determine the radionuclide efficiencies with reasonable accuracy, it is important to characterize the geometry of the solid film with some degree of precision.

The thin portion of the film surrounding the thick patch, or patches, is usually non-uniform. For films in windowless  $2\pi$  detectors (detectors that have no air layer or entrance window so that the P10 gas is in contact with the sample) where the film thickness does not exceed  $z_{\max}$ , the radionuclide efficiency diminishes linearly with the standard deviation of the film thickness, regardless of the details of the film geometry. Consequently, the thin portion of the film will be modeled using a geometry in which it is relatively easy to alter the standard deviation of the film and in which it is relatively easy to perform efficiency calculations.

Let the probability of finding a patch of thickness  $t$  be  $f(t)$ . Then the fraction of the film between the thickness  $t$  and the thickness  $t + dt$  is  $f(t)dt$ . An equation is needed for  $f$ . A function that satisfies the above requirements for ease of varying the standard deviation and ease of computation is given by

$$f = \begin{cases} 0 & \text{if } t < t_1, \\ \frac{1}{t_2 - t_1} & \text{if } t_1 \leq t \leq t_2, \\ 0 & \text{if } t > t_2, \end{cases} \quad (2)$$

where  $t_1$  is the minimum thickness of the film and  $t_2$  is the maximum thickness of the film. Thus,  $f$  is constant for a film thickness between  $t_1$  and  $t_2$ , and is zero elsewhere. The average thickness  $\langle t \rangle$  and the standard deviation  $\sigma$  of the film thickness are given by

$$\langle t \rangle = \frac{1}{2}(t_1 + t_2) \quad \text{and} \quad \sigma = \frac{1}{2\sqrt{3}}(t_2 - t_1),$$

respectively.

The area of the thick patch usually increases with the mass of the film. It was found that if the total film mass  $m_F$  is expressed in grams, then assuming that the thick patch has a mass  $m_P$  of

$$m_P = 75m_F^2 \quad (3)$$

and a thickness of 0.1 mm gave results in reasonable agreement with experiment as will be shown in Section 3.2. This equation is in reasonable agreement with visual observations of the films, although more work must be done to better quantify the relationship between  $m_P$  and  $m_F$ .

**2.7. Monte-Carlo simulations.** Monte-Carlo simulations are used to determine the efficiencies of the various alpha-emitting radionuclides. The idea behind Monte-Carlo simulations is relatively simple. In the present model it is assumed that each radionuclide is uniformly distributed in the solid film. Consequently, if some volume element  $\Delta V_1$  of the film is chosen at random, the probability of finding a given radionuclide in  $\Delta V_1$  will be the same as the probability of finding the same radionuclide in another volume element  $\Delta V_2$  of same size. In this simulation, a function called a random number generator is used to obtain three random numbers. Then an algorithm uses the three random numbers to pick a point in the solid film. The algorithm is such that if the film was partitioned into volume elements each of the same size, then the point determined by the algorithm and the three random numbers would have an equal probability of being placed within any of the volume elements of the partition. Thus, when the process of placing a radionuclide in the film, using the algorithm and the random number generator, is repeated a large number of times, one finds that the points representing the radionuclides are evenly dispersed throughout the volume of the solid film.

When a radionuclide emits an alpha particle, the alpha particle is emitted with equal probability in any direction. Once a radionuclide is located within the film, the random number generator is used to obtain two more numbers. A second algorithm uses these two numbers to fix a direction in which the alpha particle is emitted. Because the two numbers are picked at random, the alpha particle is equally likely to be emitted in any direction. Once the position of the alpha particle is fixed in the solid film and the direction in which the alpha particle is emitted is fixed, one can determine whether the trajectory of the alpha particle is oriented towards the detector, and, if it is, whether the alpha particle has enough energy to reach the detector. If the alpha particle has enough energy to reach the detector, one can determine whether the alpha particle deposits a sufficient amount of energy in the live region of the detector to cause a measurable pulse. If one repeats this process  $N_T$  times, then the radionuclide efficiency  $\varepsilon$  is given by

$$\varepsilon = N_D/N_T,$$

where  $N_D$  is the number of times that an alpha particle causes a pulse in the detector.

**2.8. Contribution of a radionuclide activity to the gross alpha activity.** The first step in the implementation of EPA Method 900.0 is to generate an efficiency, or calibration, curve. Water samples are spiked with a known activity of the calibration standard, either natural uranium or Th-230. The spiked sample is prepared and analyzed like any other sample tested for gross alpha activity. The amount of the calibration standard added to the sample is chosen such that the activity of the calibration standard far exceeds the alpha activity of any of the naturally occurring radionuclides in the sample. The efficiency  $\varepsilon_S$  of the calibration standard is defined as the ratio of the number of pulses  $N_S$  counted by the gas proportional counter per unit time to the activity  $A_S$  of the calibration standard added to the sample; i.e.,  $\varepsilon_S = N_S/A_S$  or

$$A_S = N_S/\varepsilon_S . \quad (4)$$

The efficiency of the calibration standard,  $\varepsilon_S$ , is determined for a range of water volumes to obtain a range of solid film masses. Then a calibration curve of the efficiency of the calibration standard versus the film mass is generated. When actual samples are analyzed, the mass of the solid film in the planchet is used to obtain an efficiency from the calibration curve. The method implicitly assumes that this efficiency is the same for all of the radionuclides in the solid film. From the discussion in Section 2.3, it is clear that this is not true. The radionuclides with the highest alpha-particle energies have the highest efficiencies.

Suppose that a given radionuclide has an efficiency  $\varepsilon_R$  and an activity  $A_R$ . Then the number of counts that it would generate in the gas proportional counter per unit time is just  $\varepsilon_R A_R$ . Using equation (4), the activity  $A_{R,calc}$  that would be calculated for this radionuclide would be

$$A_{R,calc} = \frac{\varepsilon_R}{\varepsilon_S} A_R . \quad (5)$$

Thus, when  $\varepsilon_R > \varepsilon_S$ , the calculated activity exceeds the actual activity of the radionuclide in the sample by a factor of  $\varepsilon_R/\varepsilon_S$ . Consequently, in samples that contain Ra-224 and Ra-226, and their short-lived, high-energy progeny, the gross alpha activity often greatly exceeds the actual alpha activity of the sample. Equation (5) also shows that the measured gross alpha activity will depend on the calibration standard that is used. A calibration standard with a higher energy alpha particle will yield a lower gross alpha. Some specific examples will be given in Section 3.7.

**2.9. Summary of model and calculations.** First the electric field in the detector is calculated so that the live and dead regions of the detector can be determined. For a given film mass the characteristics of the thin portion of the film are given by equation (2) and the characteristics of the thick patch are given by equation (3). Next a Monte-Carlo simulation is performed to determine the efficiency of each radionuclide in the film. Once the efficiency of each radionuclide is determined, including the efficiency of the calibration standard, the amount of each radionuclide in the film is determined. It is assumed that at the time that the planchet is fired, the amounts of Rn-222 and Rn-220 in



the solid film are both zero, due to their volatility. The activities of U-234, U-238, Ra-226, and Po-210 in the film are determined from their measured activities in the groundwater samples. After the sample has been heated, the activities of the alpha-emitting Ra-226 progeny (Rn-222, Po-218, and Po-214) are determined using the Bateman equations. Once the activity and efficiency of the each radionuclide is determined, Equations (5) can be used to calculate the contribution of each radionuclide to the gross alpha activity of the water sample. If the water sample contains a significant amount of Ra-228, then one usually finds that the calculated gross alpha is significantly less than the measured gross alpha, unless the time between sample collection and analysis is long compared to the half-life of Ra-224. If not, the amount of Ra-224 required to elevate the calculated gross alpha activity to the measured gross alpha activity is determined. This requires that the efficiencies of Ra-224 and its alpha-emitting progeny (Rn-220, Po-216, Bi-212, and Po-212) be determined, and that the activities of the alpha-emitting progeny of Ra-224 be determined using the Bateman equations.

### 3. Results and Discussion.

**3.1. Demonstration for the need of a cutoff field.** Before proceeding to model the data, a demonstration of the necessity of having a cutoff field  $E_{cut}$  dividing the detector into a live region and a dead region is in order. Figure 10 shows simulated Th-230 calibration curves for four values of  $E_{cut}$ —0, 100, 150, and 200 V/cm. In these calculations it was assumed that the solid film was uniform and that the threshold energy required to be deposited in the live region was 0.5 MeV. A mesh spacing of 0.5 mm was used in the finite-difference method to determine the electric field in the detector. It should be noted that the finite-difference solution to the electric field more closely approaches the actual solution as the mesh-point spacing is reduced. It is observed that as the mesh point spacing is reduced, for a given value of  $E_{cut}$ , the efficiency decreases. Consequently, to obtain accurate results, reducing the mesh point spacing is important. However, reducing the spacing of the mesh points increases the number of mesh points. For example, if the spacing between mesh points is halved, the number of mesh points increases by about a factor of eight. Thus, more computing time is required. Future work involves reducing the mesh point spacing while keeping the computing time within manageable limits.

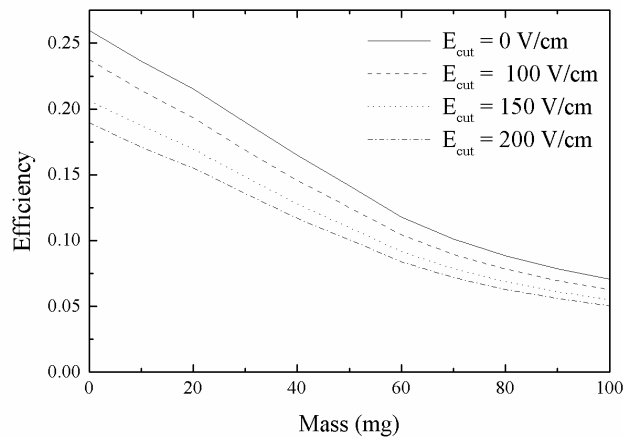

**Figure 10.** Graph of Th-230 calibration curve for various values of the cutoff field  $E_{cut}$ . The film is uniform, the mesh spacing is 0.5 mm, the required energy to be deposited in the live region is 0.5 MeV.

Figure 10 shows that at zero film mass the efficiency obtained when the cutoff field is zero is about 26% while the efficiency obtained when the cutoff field is 200 V/cm is about 18%, which is very close to the experimental value. Thus, not accounting for the dead region of the detector would introduce an error in the efficiency of about 40%.

**3.2. Simulation of a calibration curve.** Before any results can be calculated using the model, some of the parameters used by the model must be determined. For example, the cutoff field,  $E_{\text{cut}}$ , between the dead and the live regions of the detector, the minimum amount of energy  $E_{\text{Trip}}$  that must be deposited in the live region of the detector to cause a measurable pulse, and the characteristics of the film geometry must be determined before a simulation can be performed. These parameters are determined by comparing experimentally generated calibration curves for Th-230 and Am-241 to the corresponding calibration curves generated by the model. If the calibration curves generated by the model deviate too much from the experimental calibration curves, then one can adjust one or more of the parameters and generate a new set of calibration curves. This process is iterated until there is acceptable agreement between the experimental calibration curves and the calibration curves generated by the model. Figures 11 and 12 compare the experimental calibration curves to the calibration curves derived from the iterative process discussed above.

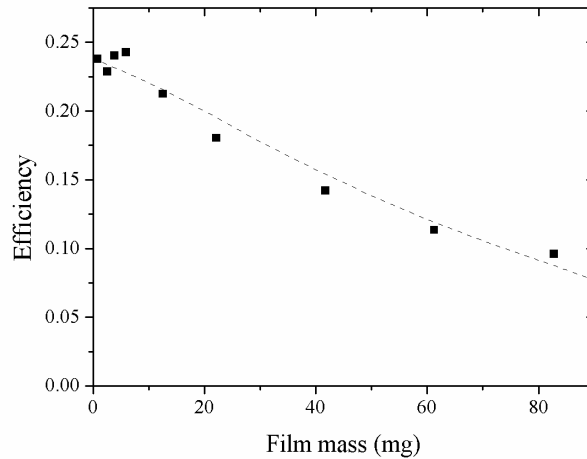

**Figure 11.** Fit to a Am-241 calibration curve. The squares represent the actual data points. The dashed line was calculated using the model.

The mass of the thick patch of the solid film was determined using Equation (3). This patch was assumed to have a thickness of 0.1 mm. The area of the planchet covered by the thick patch is just  $m_p/(0.1\rho_F)$ , where  $\rho_F$  is the density of the solid film. The solid film density was assumed to be 3.3 g/cm<sup>3</sup>. (For thin films, i.e., films without a thick patch, the radionuclide efficiencies are nearly independent of the film density. The main effect of the film density is that it determines the size of thick patch.) Since the remaining area is covered by the thin film, and the mass of the thin film is just  $m_F - m_p$ , the average thickness  $\langle t \rangle$  of the thin portion of the solid film is easily calculated. The choice of parameters used in Equation (2) are  $t_1 = 0$ ,  $t_2 = 2\langle t \rangle$ , and  $\sigma = \langle t \rangle/3^{1/2}$ , which is the maximum allowable value of the standard deviation. The cutoff field,  $E_{\text{cut}}$ , that divides

the dead region of the detector from the live region is 150 V/cm. The threshold energy,  $E_{\text{Trip}}$ , required to be deposited in the live region of the detector is 0.5 MeV. This value of the threshold energy may be somewhat high, although it is found that the gross alpha activities calculated below are nearly constant for threshold energies ranging from 0.25 to 0.75 MeV.

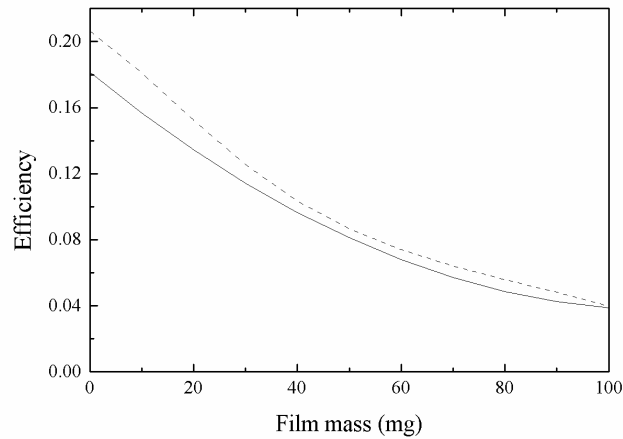

**Figure 12.** Fit to Th-230 calibration curve. The solid line represents the actual data. The dashed line was calculated using the model.

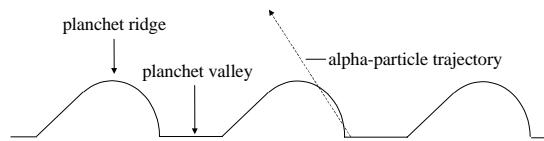

**Figure 13.** Schematic of the groove in the bottom of the planchet.

It is seen that the data models the Am-241 calibration curve rather well. The data for the Th-230 calibration curve is somewhat high. Reducing the mesh point spacing will yield more accurate results for the electric field in the detector and will reduce the efficiency somewhat. However, it is probable that there is another factor affecting the efficiency. It is seen that at zero mass the calculated efficiency is higher than the experimental efficiency. Since the mass at this point is virtually zero, the film mass and composition cannot be the cause of the elevated efficiency. In the model it is assumed that the bottom of the planchet is a flat. Actually, as shown in Figure 13, there are grooves on the bottom of the planchet. The purpose of the grooves is to distribute the sample more evenly in the planchet. The film in the planchet tends to sit in these grooves. When an alpha particle is emitted from the bottom of a groove, it is possible that the trajectory of the alpha particle is such that although it points towards the detector, it passes through a ridge of the

planchet where the alpha particle is either absorbed or losses enough energy such that it is absorbed before reaching the detector. Future refinements of the model involve taking the absorption of alpha particles by the planchet ridges into account. Unless specific mention is made to the contrary, the values of  $E_{cut}$ ,  $E_{trip}$ , and the parameters of the film geometries used for the calibration curves in Figures 11 and 12 will be used in the calculations presented below.

**3.3. Gross alpha simulation of an actual sample.** The results of the gross alpha activity calculations of all of the samples analyzed in this study are given in Appendix B. The results of the gross alpha simulation of sample 78177 are given in Table 4. The film mass was 62.9 mg. The time between sample collection and the heating of the planchet was 22.56 hrs., and the time between the heating of the planchet and the gross alpha measurement was 4.8 hrs. (The heating of the planchet is the last step in the sample preparation process.) The measured gross alpha activity of this sample was 29 pCi/L. The activity of Ra-224 required to achieve a gross alpha of 29 pCi/L was 3.52 pCi/L. The measured Ra-228 activity for this sample was 3.1 pCi/L. Thus, the ratio of the calculated activity of Ra-224 to the measured activity of Ra-228 is 1.14. Since most values of this ratio fall between 1 and 2, a value of 1.14 pCi/L is quite reasonable.

**Table 4.** Gross alpha simulation for sample 78177.

Nuclide	Efficiency	Activity (pCi/L)	Gross Alpha Contribution (pCi/L)
Th-230 Standard	0.070		
U-234	0.075	2.13	2.28
U-238	0.047	0.16	0.11
Po-210	0.102	0.01	0.02
Ra-226	0.076	3.90	4.21
Rn-222	0.111	0.14	0.22
Po-218	0.096	0.14	0.19
Po-214	0.159	0.11	0.24
Ra-224	0.118	3.52	5.94
Rn-220	0.136	3.52	6.85
Po-216	0.146	3.52	7.34
Bi-212	0.131	0.24	0.45
Po-212	0.167	0.49	1.18
		Tot. activity = 17.89	Gross Alpha = 29.00

The results of the gross activity calculations for sample 78177 are given in Table 4. The data in this table show that the total alpha activity of the water sample is 17.89 pCi/L, whereas the gross alpha activity is 29 pCi per liter. Thus, in this sample, the gross alpha activity overestimates the actual alpha activity by about 62%. This data also shows that the alpha-emitting progeny of Ra-226 (Rn-222, Po-218, and Po214) and the alpha-emitting progeny of Ra-224 (Rn-220, Po-216, Bi-212 and Po212) account for 16.47 pCi/L of the gross alpha, or 57% of the gross alpha. Consequently, these short-lived progeny of Ra-226 and Ra-224, which are never quantified in the laboratory, account for the bulk of the gross alpha activity in this sample. As discussed in Section 2.3, this is because the alpha-particle energies of these short-lived progeny are relatively high so that

their corresponding efficiencies are relatively high. This is readily seen from the data in Table 4. The efficiency of the standard Th-230 is 7.0% whereas the efficiencies of the short-lived progeny range from 9.6% to 16.7%.

As mentioned in the Introduction, many water utility operators and public health workers believe that the gross alpha activity should be equal to the sum of the total uranium activity and the Ra-226 activity. From Table 4 it is clear that this only accounts for 6.59 pCi/L of the gross alpha activity, or just 22% of the gross alpha activity.

**3.4. Effect of film roughness on the gross alpha.** In this section the effect of the solid film geometry on the gross alpha activity will be investigated. As discussed in Section 2.6, when the solid film in the planchet has a significant amount of mass, usually one or more large patches form that are surrounded by a thin film. However, occasionally, it is observed that a solid film containing a substantial amount of mass does not have a large patch. Instead although it may be somewhat rough, the film is observed to cover the entire planchet with some degree of uniformity. In this section when the term rough film is used, it is understood that the same parameters are used in the calculations in this section that were used in Section 3.2. That is, the film has a one or more large patches surrounded by a thin film. When the term uniform film is used, it is understood that the film is of uniform thickness over the whole area of the planchet.

**Table 5.** Gross alpha simulation for rough and uniform film geometries.

Th-230 film geometry	Sample film geometry	Gross Alpha (pCi/L)
Rough	Rough	1.75
Uniform	Uniform	1.71
Rough	Uniform	2.17

Some calculations were performed to demonstrate how the geometry of the film affects the gross alpha activity. A summary of these results is given in Table 5 for a water sample containing 1 pCi of U-238 and 1 pCi of U-234 and having a film mass of 50 mg. In the first case, when both the film of the calibration standard and the film of the sample are rough, the gross alpha is 1.75 pCi/L. In the second case, when both the film of the calibration standard and the film of the sample are uniform, the gross alpha activity is nearly the same as in the first case. However, in the third case, when the film of the calibration standard is rough and the film of the sample is uniform, the gross alpha activity is 2.17 pCi/L. Thus, in the third case the gross alpha activity has increased by about 27% relative to the other two cases, and it is clear that the film geometry alone can have a substantial effect on the gross alpha activity.

**3.5. Determination of uranium activity for the computation of the adjusted gross alpha activity.** The adjusted gross alpha activity of a water sample is equal to the gross alpha activity of the water sample minus the total uranium activity of the water sample. In common practice there are two ways of determining the total uranium activity of a water sample. In the first method, the total uranium activity of the sample is measured directly by a radiochemical method. EPA Method 908.0<sup>22</sup> is one such method. In the second method, which will be referred to as the gravimetric method, the total uranium mass of the sample is measured, and, then, the total uranium mass is converted into a total

uranium activity. EPA Method 908.1<sup>23</sup> is gravimetric method in which the total uranium mass is determined fluorometrically. In order to convert the total uranium mass to a total uranium activity, one must make an assumption about the relative abundances of the uranium isotopes in the water sample. In general, it is assumed that the uranium isotopes are in natural abundance. Below, it is shown that a consequence of this assumption is that the total uranium activity of a water sample, using the gravimetric method, is approximately equal to twice the U-238 activity of the water sample, regardless of the U-234 activity.

There are three naturally occurring isotopes of uranium: U-234, U-235, and U-238. On a gravimetric basis the relative abundances of U-234, U-235, and U-238 are 0.0054%, 0.7110%, 99.2830%, respectively. Although the abundance of U-234 is much less than the abundance of U-238 on a gravimetric basis, U-234 is in secular equilibrium with U-238, so that when all of the media containing these isotopes is taken into account, the activity of U-234 must equal the activity of U-238. As was discussed in Section 1.1, it is known that groundwater samples are often enriched in U-234 relative to U-238. In such samples it is not unusual for the U-234 activity to exceed the U-238 activity by a factor of five (see data in Appendix A).

The alpha activity  $A$  of a particular uranium isotope is just  $\lambda N$ , where  $\lambda$  is the decay constant of the uranium isotope and  $N$  is the number of atoms of the uranium isotope. Now  $N = mN_0/W$ , where  $m$  is the mass of the uranium isotope,  $N_0$  is Avogadro's number, and  $W$  is the atomic weight of the uranium isotope. If  $m$  is the mass of the isotope,  $m_T$  is the total uranium mass, and  $f$  is the fractional abundance of the uranium isotope, then

$$A = \frac{\lambda}{W} N_0 m = \frac{\lambda}{W} f N_0 m_T. \quad (6)$$

The total uranium activity,  $A_T$ , is just the sum of three such terms, one for each uranium isotope:

$$A_T = \left( \frac{\lambda_{U-234}}{W_{U-234}} f_{U-234} + \frac{\lambda_{U-235}}{W_{U-235}} f_{U-235} + \frac{\lambda_{U-238}}{W_{U-238}} f_{U-238} \right) N_0 m_T.$$

If U-234 and U-238 are in secular equilibrium, or in natural abundance, then the first and the third terms in the parentheses are equal. If one assumes that the three uranium isotopes are in natural abundance, then, for the purpose of making a calculation, the factor enclosed in parentheses is constant, and the only term that varies is  $m_T$ . That is,

$$A_T = km_T = k(m_{U-234} + m_{U-235} + m_{U-238}), \quad (7)$$

where  $m_{U-234}$ ,  $m_{U-235}$ , and  $m_{U-238}$  are the masses of U-234, U-235, and U-238, respectively; and the constant  $k$  is given by

$$k = \left( \frac{\lambda_{U-234}}{W_{U-234}} f_{U-234} + \frac{\lambda_{U-235}}{W_{U-235}} f_{U-235} + \frac{\lambda_{U-238}}{W_{U-238}} f_{U-238} \right) N_0.$$

A simple calculation shows that  $k = 0.684 \text{ pCi}/\mu\text{g}$ .

Since U-238 accounts for most of the total uranium mass, it is seen that the total uranium activity calculated by Equation (7) would be rather insensitive to the mass of U-234. The following example demonstrates this point. Consider two water samples that are identical in all respects except for the amount of U-234 contained in them. Both samples contain 1 pCi of U-238 and that amount of U-235 that is in natural abundance with 1 pCi of U-238. The first sample contains that amount of U-234 that is in secular equilibrium with U-238; i.e., the first sample contains 1 pCi of U-234. The second sample is assumed to be enriched in U-234 and to contain 5 pCi of U-234. From Equation (6) it is found that both samples contain  $3.00 \mu\text{g}$  of U-238. Assuming U-235 to be in natural abundance with U-238, both samples contain  $0.0213 \mu\text{g}$  U-235, or, from Equation (6),  $0.0017 \text{ pCi}$  U-235, an activity which for our purposes is negligible. From Equation (6) it is found that the first sample contains  $1.62 \times 10^{-4} \mu\text{g}$  of U-234, and that the second sample contains  $8.09 \times 10^{-4} \mu\text{g}$  of U-234. Thus, both samples contain about  $3.02 \mu\text{g}$  of total uranium. From Equation (7), the percent difference in activities between the two samples, using the gravimetric method, is

$$\frac{k(8.09 \times 10^{-4} - 1.62 \times 10^{-4})}{k3.02} \times 100 \approx 0.02\% .$$

Consequently, using the gravimetric method, there is scarcely any difference between the total uranium activities of the two samples. The total uranium activity for either sample is approximately equal to twice the U-238 activity, and, using the gravimetric method, the calculated value of the total uranium activity for the second sample would be about 2 pCi when it is actually about 6 pCi. The error of 4 pCi for total uranium activity incurred using the gravimetric method could be the cause of a gross alpha violation when no gross alpha violation actually exists. Because of the large discrepancy between the U-234 and U-238 masses in most samples, the gravimetric method will almost always yield a total uranium activity that is just equal to twice the U-238 activity.

**3.6. Effect of sample collection, preparation, and analysis time on gross alpha activity and sample compliance.** In this laboratory it is not an uncommon occurrence that a sample is analyzed that has no radium violation but has a gross alpha violation. Such a situation may be due to the error inherent in the gross alpha measurement, but it is possible for such a situation to occur when no error has been committed. The example presented in this section will demonstrate such a case. This example will also demonstrate the inherent variability of the gross alpha activity with the sample collection, preparation, and analysis times. It is not uncommon for a customer to send a water sample for gross alpha analysis to several laboratories, and to find that there is widespread disagreement among the gross alpha activity results obtained by the various laboratories. Such differences are not unexpected when one takes into account all of the factors that affect the gross alpha measurement.

Consider a sample that contains 2 pCi/L of Ra-226, 2 pCi/L of Ra-228, 3 pCi/L of Ra-224, 1 pCi/L of U-238, and 5 pCi/L of U-234. Such a sample would have no radium violation since the sum of the Ra-226 and Ra-228 activities is 4 pCi/L. If this sample is

prepared one day after collection, and if the planchet is allowed to sit for three days before analysis, then a calculation (see Table 6) yields a gross alpha activity of 23.12 pCi/L and an adjusted gross alpha activity of 17.12 pCi/L. Thus, it is seen that, for regulatory purposes, there is no radium violation, but, due to the presence of Ra-224 and its short-lived progeny, there is a gross alpha violation. Such situations cause confusion among both chemists and clients because one is not able to identify the source of the gross alpha violation. Often the chemist will perform the measurement on the planchet again. In this example if the planchet is reanalyzed 7 days after it was prepared, one would obtain a gross alpha activity 20.38 pCi/L and an adjusted gross alpha activity 14.38 pCi/L. Now the sample is in compliance. The reduction in the gross alpha activity occurred because the increase in the part of the gross alpha activity due to the Ra-226 progeny is less than the decrease in the part of the gross alpha activity due to Ra-224 and its progeny. If one waits until all of the Ra-224 has decayed away and the progeny of Ra-226 have come into secular equilibrium with Ra-226, then the gross alpha activity would be 18.12 pCi/L and the adjusted gross alpha activity would be 12.12 pCi/L. In this example it has been assumed that the total uranium activity was determined directly. If the total uranium activity had been determined using a gravimetric method, then the total uranium activity would have been determined to be 2 pCi/L rather than 6 pCi/L, and the sample would have had a gross alpha violation regardless of how long it had sat before sample analysis.

**Table 6.** Gross alpha calculation for a sample that contains 2 pCi/L Ra-226, 2 pCi/L Ra-228, 3 pCi/L of Ra-224, 1 pCi/L U-238, and 5 pCi/L U-234.

Nuclide	Efficiency	Activity (pCi/L)	Gross Alpha (pCi/L)	Activity (pCi/L)	Gross Alpha (pCi/L)	Activity (pCi/L)	Gross Alpha (pCi/L)
Time delay (Days)		3	3	7	7	No Ra-224	No Ra-224
Th-230 Std	0.085						
U-234	0.091	5.00	5.33	5.00	5.33	5.00	5.33
U-238	0.058	1.00	0.68	1.00	0.68	1.00	0.68
Ra-226	0.092	2.00	2.15	2.00	2.15	2.00	2.15
Rn-222	0.132	0.84	1.29	1.44	2.21	2.00	3.08
Po-218	0.116	0.84	1.13	1.44	1.94	2.00	2.70
Po-214	0.179	0.83	1.73	1.43	3.00	2.00	4.18
Ra-224	0.139	1.40	2.28	0.65	1.06	0	0
Rn-220	0.157	1.40	2.57	0.65	1.20	0	0
Po-216	0.167	1.40	2.73	0.65	1.28	0	0
Bi-212	0.152	0.53	0.96	0.25	0.45	0	0
Po-212	0.185	1.05	2.27	0.50	1.08	0	0
Total (pCi/L)			23.12		20.38		18.12

Due to sample backlogs, it is not unusual for a sample to be in storage for a month before a gross alpha analysis is performed on it. Over this period of time most of the Ra-224 activity will have decayed away. Table 7 gives the results for a sample held for 30 days before processing and analyzed 3 days after firing. This sample has the same



radiochemical composition as the sample whose results are given in Table 6. For this sample the gross alpha activity is 12.36 pCi/L and the adjusted gross alpha 6.36 pCi/L. The results summarized in Tables 6 and 7 demonstrate that the time between sample collection and preparation and between sample preparation and analysis can determine whether a sample is in or out of compliance. These results also demonstrate the variability of the gross alpha activity as a function of sample collection, preparation, and analysis time. Even more variability among laboratories could occur if not all of the laboratories use the same calibration standard. The variability of the gross alpha activity as a function of the calibration standard is the topic of the next section.

**Table 7.** Gross alpha calculation for a sample prepared 30 days after collection.

Nuclide	Efficiency	Activity (pCi/L)	Gross Alpha (pCi/L)
Standard	0.085		
U-234	0.091	5.00	5.33
U-238	0.058	1.00	0.68
Ra-226	0.092	2.00	2.15
Rn-222	0.132	0.84	1.29
Po-218	0.116	0.84	1.13
Po-214	0.179	0.83	1.73
Ra-224	0.139	0.01	0.01
Rn-220	0.157	0.01	0.01
Po-216	0.167	0.01	0.01
Bi-212	0.152	0.00	0.00
Po-212	0.185	0.00	0.01
Total		10.53	12.36

**3.7. Effect of the calibration standard on gross alpha activity.** Since the various calibration standards have different efficiencies, and since it is implicitly assumed that the efficiencies of all of the radionuclides in the solid film have the same efficiency as the calibration standard, it is clear that the gross alpha activity of the sample will depend on the choice of calibration standard.

EPA Method 900.0<sup>2</sup> allows for the use of either natural uranium or Th-230 as the calibration standard. EPA Method 900.1<sup>3</sup> allows for the use of Th-230 or Am-241 as the calibration standard. Prior to 1995, EPA Method 900.0 allowed for the use of Am-241 as the calibration standard. Consequently, there may be some confusion over the use of Am-241 for Method 900.0, and it is possible that some laboratories may still be using Am-241 as the calibration standard for this method.

For a 50 mg solid film the efficiencies of natural uranium, Th-230, and Am-241 are 0.07462, 0.08557, 0.13109, respectively. From Equation (5) the percent change in the gross alpha activity in going from a calibration standard of efficiency  $\epsilon_{S,1}$  to a calibration standard of efficiency  $\epsilon_{S,2}$  is given by

$$\left( \frac{A_{R,calc,2} - A_{R,calc,1}}{A_{R,calc,1}} \right) \times 100\% = \left( \frac{\varepsilon_{S,1}}{\varepsilon_{S,2}} - 1 \right) \times 100\% . \quad (4)$$

For a 50 mg solid film Table 8 shows the percent change in the gross alpha activity that is incurred in going from one calibration standard to another. From this data it is clear that the choice of a calibration standard can have a substantial effect on the gross alpha activity. Evidently, the choice of the calibration standard alone can determine whether a water sample has a gross alpha violation or not.

**Table 8.** Percent change in the gross alpha activity between two calibration standards for a 50 mg film.

		Second calibration standard.		
		Natural U	Th-230	Am-241
First calibration standard	Natural U	1	-12.8	-43.1
	Th-230	14.7	1	-34.7
	Am-241	75.7	53.2	1

With many methods available and a choice of calibration standards, one might wonder which method and which calibration standard will give the most accurate results. The fact is that it depends on which radionuclides are in the sample. Some water samples contain uranium and very little radium. If the uranium in the sample is present in natural abundance, then, of course, the use of natural uranium as the calibration standard would give the most accurate results. However, typically, the water sample is enriched in U-234 relative to U-238. Suppose the sample has 1 pCi/L of U-238 and 5 pCi/L of U-234. Then, for a 50 mg solid film, the gross alpha activities calculated using natural uranium, Th-230, and Am-241 as the calibration standards are 6.895, 6.013, and 3.925 pCi/L, respectively, as shown in Table 9. From Table 3 it is seen that the alpha-particle energies for U-234 and Th-230 are relatively close, and since most of the activity in the sample is from U-234, using Th-230 as the calibration standard gives the most accurate results.

**Table 9.** Affect of calibration standard on the gross alpha of a sample containing uranium.

Nuclide	Efficiency	Activity (pCi/L)	Natural uranium Gross Alpha (pCi/L)	Th-230 Gross Alpha (pCi/L)	Am-241 Gross Alpha (pCi/L)
U-234	0.09126	5.000	6.116	5.333	3.481
U-238	0.05815	1.000	0.779	0.680	0.444
	Total	6.000	6.895	6.013	3.925

Some samples contain radium and little uranium. Often water samples are stored for a period of time before the gross alpha procedure is performed on them. EPA Method 900.0 allows samples to be stored for a period of up to six months before sample preparation. Since Ra-224 has a half-life of 3.64 days, if a water sample is stored for a period of about a month or more, then most of the Ra-224 activity will have decayed

away. The gross alpha method stipulates that once the sample is prepared it should be stored for at least three days prior to measuring its gross alpha activity. This allows the progeny of Ra-226 to grow in, although, as Figure 3 shows, after three days they are not in secular equilibrium with Ra-226. Suppose that a water sample has 2 pCi/L of Ra-226, and that all of the Ra-224 has decayed away. Three days after sample preparation, the total alpha activity in the solid film is 4.487 pCi/L. For a 50 mg solid film the gross alpha activity calculated using natural uranium, Th-230, and Am-241 as the calibration standards is 7.230 pCi/L, 6.305 pCi/L, and 4.115 pCi/L, respectively, as shown in Table 10. Thus, although Th-230 gives the most accurate results for Ra-226 (2.151 pCi/L), Am-241 gives the gross alpha activity that is closest to the actual alpha activity of the sample. The reason for this is that the alpha-particle energy of Am-241 is closer to the alpha-particle energies of the Ra-226 progeny, which make up the bulk of the activity in the sample.

**Table 10.** Affect of calibration standard on the gross alpha of a sample containing Ra-226.

Nuclide	Efficiency	Activity (pCi/L)	Natural uranium Gross Alpha (pCi/L)	Th-230 Gross Alpha (pCi/L)	Am-241 Gross Alpha (pCi/L)
Ra-226	0.09201	2.000	2.466	2.151	1.404
Rn-222	0.13162	0.839	1.480	1.290	0.842
Po-218	0.11550	0.839	1.297	1.131	0.738
Po-214	0.17898	0.829	1.987	1.732	1.131
	Total	4.487	7.230	6.305	4.115

**Table 11.** Affect of calibration standard on the gross alpha of a sample containing Ra-224.

Nuclide	Efficiency	Activity (pCi/L)	Natural uranium Gross Alpha (pCi/L)	Th-230 Gross Alpha (pCi/L)	Am-241 Gross Alpha (pCi/L)
Ra-224	0.139008	1.401	2.609	2.275	1.485
Rn-220	0.1571527	1.401	2.950	2.573	1.679
Po-216	0.1669641	1.401	3.135	2.733	1.784
Bi-212	0.1517508	0.534	1.086	0.947	0.618
Po-212	0.1848945	1.051	2.604	2.270	1.482
	Total	5.788	12.384	10.799	7.049

Although it is unlikely that that a water sample would contain Ra-224 without containing Ra-226, it is informative to determine how well the use of each calibration standard approximates the activity of Ra-224 and its alpha-emitting progeny. It is assumed that a water sample contains 3 pCi/L of Ra-224, that there is one day between sample collection and sample preparation, and 3 days between sample preparation and sample analysis. The portion of the gross alpha activity due to Ra-224 and its progeny for the 3 calibration standards is given in Table 11. It is seen that each calibration standard overestimates the

alpha activity of the sample. Although Am-241 comes the closest to actual alpha activity of the sample, the alpha activity using Am-241 is still overestimated by 22%.

**3.8. Discussion of data for the groundwater samples.** Table 18 in Appendix B gives a summary of the gross alpha activity calculations for the 98 samples analyzed in this study. Included in the table for each sample is the solid film mass, the time between sample collection and sample preparation, the time between sample preparation and sample analysis, and the measured gross alpha activity. A calculated gross alpha activity is also included in which it was assumed that Ra-224 was in secular equilibrium with Ra-228 at the time of sample collection, i.e., that the Ra-224 activity equaled the Ra-228 activity. In general, it is found that the Ra-224 activity exceeds the Ra-228 activity. Consequently, the amount of Ra-224 required to be present in the original sample to attain the measured gross alpha activity was also determined and included in Table 18. This calculation was not performed for samples in which the gross alpha activity was determined 30 to 60 days after sample collection, since the Ra-224 activity would have decayed away by then. These include samples in which the first analysis did not meet quality control standards, so that they had to be reanalyzed. The measured value of the Ra-228 activity for each sample is included in Table 18, and the ratio of the calculated Ra-224 activity to the measured Ra-228 activity is also included. This ratio is referred to as the Ra-224/Ra-228 ratio below.

It is seen that 71 samples have radium violations; i.e., the combined activity of Ra-226 and Ra-228 exceeds 5 pCi/L. Eight of the samples had a gross alpha violation when there was no radium violation. These are samples in which the adjusted gross alpha exceeds 15 pCi/L, but the combined activity of Ra-226 and Ra-228 is less than 5 pCi/L. In addition, if a gravimetric method were used to determine the total uranium activity, there would be an additional 5 samples which would have a gross alpha violation but no radium violation. In this study the samples were analyzed soon after sample preparation, rather than the requisite 3 days required by Method 900.0, in order to observe the effect Ra-224 and its progeny on the gross alpha activity. Undoubtedly, some of the samples having gross alpha violations would not have gross alpha violations if the samples were allowed to sit long enough for the Ra-224 to decay away.

Out of the 98 samples that were analyzed, 78 were analyzed within about 15 days of sample collection. Out of the 78 samples, 5 samples had negative Ra-224/Ra-228 ratios, and sample 80732 had a Ra-224/Ra-228 ratio of 71.82. The Ra-224/Ra-228 ratios for the remaining 72 samples are plotted as a histogram in Figure 14. In Figure 14 the *x*-axis is divided into segments of 0.25 units, and the *y*-axis gives the number of samples falling within a given 0.25 unit range. Most of the Ra-224/Ra-226 ratios fall within the 0.50 to 3.50 range with 43 samples falling within the 1.00 to 2.00 range. The Ra-224/Ra-228 ratio exceeded 3.5 for three of these samples (samples 80737, 80743, 80264). Some data for these three samples and sample 80732 are summarized in Table 12. The data in this table includes the error in the experimentally determined gross alpha activities. Errors in the calculated gross alpha activities were not determined, although such an error analysis will be performed in future work. From the table it is seen that the experimental gross alpha activity for sample 80737 agrees with the calculated gross alpha activity to within the experimental error. The calculated gross alpha activities for the other 3 samples are

not within the error of the experimentally determined gross alpha activities. Although a complete error analysis was not performed for the calculated Ra-224/Ra-228 ratios, some simple error estimates will demonstrate whether the Ra-224/Ra-228 ratios for the other samples are within acceptable error limits.

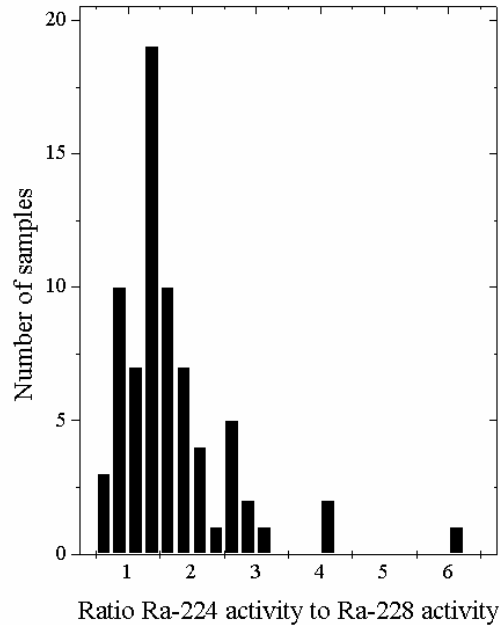

**Figure 14.** Histogram of Ra-224/Ra-228 ratios.

In section 3.4 it was shown that if a 50 mg solid film is of uniform thickness, i.e., if the film is smooth, the corresponding gross alpha activity of the sample can be elevated by about 27% relative to the case in which the solid film is rough. The data in Table 12 show that when the calculated gross alpha activities are increased by 27%, the experimental and calculated gross alpha activities are in agreement for samples 80737 and 80743. If the experimental Ra-228 activity error is taken into account, then it is seen that the Ra-224/Ra-228 ratios for the samples 80737 and 84264 are can be as low as 1.67 and 2.66 respectively. Consequently, when a full error analysis is performed, it is likely that the Ra-224/Ra-228 ratios for samples 80737, 80743, and 84264 will, within experimental error, fall within the normal range of 1 to 2.

Sample 80732 seems to be an exception. This sample contained 6.17 pCi/L of Po-210. It is known that Po-210 is not very stable in many solutions and begins to hydrolyze at a pH of about 2.5. Consequently, it can be difficult to keep Po-210 in solution. In general, the samples were prepared for gross alpha analysis within a few days of arrival at the laboratory, whereas analysis for Po-210 could take weeks. It is possible that some of the Po-210 originally in the solution precipitated from solution and was lost. From Table 3 it is seen that the alpha-particle energy of Po-210 is significantly larger than the alpha-particle energy of Th-230. For a 44.7 mg solid film the Th-230 efficiency is 0.09369 and the Po-210 efficiency is 0.13151. The difference between the measured and the calculated

gross alpha activities is about 68 pCi/L, so the amount of Po-210 required to make up this deficit would be  $(68 \times 0.0937) / 0.132 = 48$  pCi/L. It is difficult to determine whether this is a reasonable number since so few studies have quantified the Po-210 activity in groundwater samples.

Data for the five samples in which the Ra-224/Ra-228 ratios were negative are shown in Table 13. When the error in the measured gross alpha activity is taken into account, it is seen that the measured and calculated gross alpha activities for samples 80736 and 84675 are in agreement. Samples 84271 and 84522 had negative Ra-224/Ra-228 ratios because the measured values of the Ra-228 activities were both  $-0.1$  pCi/L. If the Ra-228 activity error is taken into account, then the minimum Ra-224/Ra-228 ratios for samples 84271 and 84522 are 2.49 and 3.02, respectively. Consequently, when a complete error analysis for these samples is completed, the Ra-224/Ra-228 ratios may very well fall within the acceptable range of 1 to 2. For sample 80354 the calculated gross alpha overestimates the measured gross alpha, and, as a consequence, the calculated Ra-224 activity is negative. For this sample the gross alpha and the measured activities of the various radionuclides are relatively low and have rather high relative uncertainties; consequently, it is likely that when an error analysis is completed, it will be found that the measured and the calculated gross alpha activities agree within experimental error.

**Table 12.** Samples with Ra-224/Ra-228 ratios exceeding 3.5.

Sample ID	Gross alpha activity (pCi/L)	Gross alpha activity error (pCi/L)	Calc. gross alpha activity (pCi/L)	Smooth film gross alpha activity (pCi/L)	Calculated activity of Ra-224 (pCi/L)	Ra-228 activity (pCi/L)	Ra-228 activity error (pCi/L)	Ratio of Ra-224 to Ra-228	Po-210 activity (pCi/L)	Adjusted Ra-224 to Ra-228 ratio
80732	183	8	115.08	146.00	15.08	0.21	0.44	71.82	6.18	23.20
80737	62	6	56.13	71.30	2.33	0.56	0.84	4.17	0.05	1.67
80743	143.8	6.8	115.87	147.00	8.65	1.43	0.64	6.05	4.60	4.18
84264	16	4	7.09	9.00	3.72	0.9	0.5	4.14	0.03	2.66

**Table 13.** Samples with negative Ra-224/Ra-228 ratios.

Sample ID	Gross Alpha (pCi/L)	Gross alpha error (pCi/L)	Calc. gross alpha (pCi/L)	Solid film weight (mg)	Calculated Ra-224 activity (pCi/L)	Ra-228 activity (pCi/L)	Ra-228 Activity error (pCi/L)	Ratio of Ra-224 to Ra-228	Adjusted ratio of Ra-224 to Ra-228
80354	1	2	4.32	49.0	-0.13	0.7	0.7	-0.19	-0.09
80736	78	7	84.32	13.2	-0.65	1.26	0.73	-0.52	-0.33
84271	3	2	0.02	15.4	0.99	-0.1	0.5	-9.95	2.49
84522	4.2	1.5	0.78	36.6	0.91	-0.1	0.4	-9.06	3.02
84675	41	5	44.65	36.3	-4.18	6.1	0.8	-0.68	-0.61

In general, the Ra-224/Ra-228 ratios are close to the expected range of 1 to 2. It is likely that when a complete error analysis is performed, the majority of the Ra-224/Ra-228 ratios will, within experimental error, fall within the range from 1 to 2.

#### **4. Summary and Conclusions.**

Several steps must be taken to prepare this report for publication. The electric field in the detector should be determined with a greater degree of accuracy. This involves decreasing the mesh point spacing in the detector, and making a better initial guess of the solution to Laplace's equation. Currently, if the mesh point spacing is made too small, the solution oscillates and does not converge to the final solution in a timely manner. The calculated calibration curve for Th-230 exceeds the actual one. It is probable that the ridges in the planchet are at least partially responsible for this. Consequently, the model will be altered to take the effect of these ridges into account. Some work should be done to further characterize the geometry of the solid film, so that the calculated calibration curves for Th-230 and Am-240 are more accurate. The composition of the solid film in the planchet should be studied in order to determine whether the sulfates preferentially combine with sodium and potassium, and whether the nitrates associated with calcium and magnesium are completely decomposed to the oxides when the planchet is heated.

Figure 14 shows that most of the data for the Ra-224/Ra-228 ratios fall in or near the range from 1 to 2 as expected, demonstrating that Ra-224 is present in most of the samples at the expected levels. However, an error analysis must be made on the Ra-224/Ra-228 ratio data, and a statistical analysis must be performed to determine whether experimental error can account for the data that fall outside of the range from 1 to 2.

There is often much confusion over the meaning of the gross alpha activity. The gross alpha activity contains contributions from U-234, U-238, and Ra-226. If Th-230 is used as the calibration standard, the contributions of these radionuclides to the gross alpha activity are approximately equal to the sum of their activities, because of the closeness of their alpha-particle energies to the alpha-particle energy of Th-230. If Ra-228 is present in the sample, then the sample will contain Ra-224, unless sufficient time has passed so that it has decayed away. In general, the gross alpha activity contains contributions from the progeny of Ra-226 and Ra-224 and its progeny. In fact, because the progeny of Ra-226 and Ra-224 and its progeny have high alpha-particle energies, they can be responsible for the majority of the gross alpha activity of a sample.

This work shows that the value obtained for the gross alpha activity of a groundwater sample using EPA Method 900.0 is a function of many factors. These factors include the time between sample collection and sample preparation; the time between sample preparation and sample analysis; the radionuclide used as the calibration standard; the geometry of the solid film in the planchet; and, if the adjusted gross alpha activity must be determined, whether a radiochemical or gravimetric method is used to determine the total uranium activity. Although it was not investigated specifically in this work, the composition of the solid film probably affects the gross alpha activity as well.

It was seen that it is possible for a water sample to have a gross alpha violation (even though there is no radium violation) when prepared one way, but not to have a gross

alpha violation when prepared in another way, even though both ways of preparing the sample are within acceptable parameters set by EPA Method 900.0. In the example in Section 3.6, the cause of the gross alpha violation was due to the presence of Ra-224, a radionuclide whose activity is not routinely measured in the laboratory. This situation can be a point of frustration between a chemist and client, since the chemist often cannot attribute the gross alpha violation to a known cause. The presence of a significant level of Po-210 can also give an adjusted gross alpha activity that exceeds 15 pCi/L when no radium violation exist. In general, laboratories do not routinely test for Po-210.

There is often much confusion over the meaning of the gross alpha activity. It is often wrongly assumed that the sum of the total uranium activity and the Ra-226 activity should equal the gross alpha activity. In general, this is not the case because the alpha-emitting progeny of Ra-226 and Ra-224 and its alpha-emitting progeny contribute to the gross alpha activity also. The contribution of one of the progeny to the gross alpha activity usually exceeds its own activity, because the efficiency of the progeny significantly exceeds the efficiency of the calibration standard. With the model developed in this work, it is possible to determine the contribution of each radionuclide to the gross alpha activity. In water samples where there is gross alpha violation but no radium violation, the model could be used to determine whether the gross alpha violation could be due to the presence of Ra-224, or if some other cause should be investigated. In cases where public water supplies must be treated because of radium or gross alpha violations, such a calculation could be a valuable tool in pinning down the exact cause of the violation, and, therefore, a valuable tool in determining how the water should be treated to bring it within acceptable radiochemical limits.

It is often observed that when a sample is sent to several laboratories, one obtains widely disparate values of the gross alpha activity. This is not surprising. The higher the alpha-particle energy of the radionuclide used as the calibration standard, the lower is the measured gross alpha activity. Thus, EPA Method 900.1, in which the calibration standard Am-241 is used, would, in general, be expected to yield lower gross alpha activities than EPA Method 900.0, in which the use of Am-241 is not allowed. If there is much radium in a water sample, either Method 900.0 or Method 900.1 will yield a lower gross alpha activity if the sample is allowed to sit long enough for most of the Ra-224 to decay away. This is not only due to the decay of the Ra-224, but is due also to the disappearance of the alpha-emitting progeny of Ra-224. For example, since Ra-224 has a half-life of 3.64 days, after 30 days only about 0.33% of the original Ra-224 activity remains. Method 900.0 stipulates that once the planchet is heated, one must wait at least three days before analyzing the planchet, to allow for the ingrowth of the Ra-226 progeny. If the Ra-224 has decayed away, then to achieve the lowest gross alpha activity, the sample should be analyzed promptly after three days, because the activities of the Ra-226 progeny, and, therefore the gross alpha activity, continue to grow until secular equilibrium is reached after about 30 days. Thus, to achieve the lowest gross alpha activity one should use the calibration standard with the highest alpha-particle energy allowed (Th-230 for Method 900.0 and Am-241 for Method 900.1); one should allow the sample to sit for about 30 days before preparation, so that the Ra-224 decays away; and one should measure the alpha activity of the planchet promptly three days after sample preparation. If, alternatively, one prepares the sample soon after collection and allows the



sample to sit for 30 days, Ra-224 and its progeny will have decayed away, but the progeny of Ra-226 will have come into secular equilibrium with Ra-226. This may cause a gross alpha violation. Since the treatment of a gross alpha violation can be costly, there is undoubtedly pressure for laboratories to achieve the lowest gross alpha activities possible. Thus, in an attempt to satisfy a customer, a laboratory could easily manipulate the gross alpha analysis of a water sample, within the parameters set forth by the method, to achieve the lowest possible value for the gross alpha activity. This minimum value may be well within regulatory limits, even though other acceptable ways of sample preparation may lead to a gross alpha violation.

To achieve a higher degree of uniformity among the various laboratories, it would seem sensible to place further restrictions on the range of parameters allowed by the various methods. For example, one might require that all of the methods use the same calibration standard, that a sample be analyzed within a certain time period after collection (below, it is argued that a time period of 10 days is satisfactory), and that, for the purpose of computing the adjusted gross alpha activity, a radiochemical method be used to determine the uranium activity.

Ultimately, the purpose of a gross alpha test is to ensure that a water supply is safe from a radiological perspective, not to justify the avoidance of water treatment by manipulating the test to obtain the lowest gross alpha activity possible. Clearly, the value obtained for the adjusted gross alpha depends on many factors. Since the activity of Ra-224 and its progeny decline at a predictable rate, and since the progeny of Ra-226 grow in at a predictable rate once the sample is prepared, it is, in principle, possible to use the model outlined in this work to determine the amount of Ra-224 and Ra-226 in a sample. This might require the measurement of the gross alpha activity of the sample at several points in time. However, the calculations would be rather complicated and would probably be subject to relatively large errors. In the final analysis, it would seem that the gross alpha test is best used as a screening tool to determine whether a water sample has an uranium or a radium violation. Ra-228 is not an alpha emitter, but its activity is highly correlated with the activity of Ra-224. In the analysis that follows, it will be assumed that at the time of sample collection the Ra-224 activity,  $A_{\text{Ra-224},0}$ , equals the Ra-228 activity.

If the sample is prepared just after collection, the total activity of Ra-224 and its progeny would significantly exceed the activity of Ra-228, and, therefore, the part of the gross alpha activity due to Ra-224 and its progeny,  $G_{\text{Ra-224}}$ , would be an upper bound for the Ra-228 activity. It is clear that to a first approximation,  $G_{\text{Ra-224}}$  decays away with a half-life equal to the half-life of Ra-224, i.e., 3.64 days. It is of interest to know for what period of time after sample collection that  $G_{\text{Ra-224}}$  remains an upper bound for the original Ra-228 activity of the sample. Let this time period be denoted by  $\Delta t$ . To estimate  $\Delta t$ , an example is in order. If Th-230 is used as the calibration standard, and one has a 50 mg solid film, then, the example in Section 3.6 shows that the ratio of  $G_{\text{Ra-224}}$  to the activity of Ra-224,  $A_{\text{Ra-224}}$ , is about 7.7; i.e.,  $G_{\text{Ra-224}} = 7.7A_{\text{Ra-224}}$ . Since

$$A_{\text{Ra-224}} = A_{\text{Ra-224},0} \exp[\ln(2)t/3.64],$$

and it is desired to know the value of  $t$  when  $G_{\text{Ra-224}} = A_{\text{Ra-224},0}$ , it is clear that

$$A_{\text{Ra-224},0} \approx 7.7A_{\text{Ra-224},0}\exp[\ln(2)\Delta t/3.64].$$

Consequently,  $\Delta t \approx 10.7$  days. Thus, given the assumptions made above, if a water sample is processed and analyzed within about 10 days of collection, then  $G_{\text{Ra-224}}$  would be an upper bound on the Ra-228 activity. Moreover, since the portion of the gross alpha activity due to Ra-226 is slightly greater than the activity of Ra-226, when Th-230 is used as the calibration standard, it is clear that if the water sample is processed and analyzed within about 10 days of sample collection, the gross alpha activity will be an upper bound for the sum of the Ra-226 and Ra-228 activities. As the example in Section 3.6 shows, it is possible that processing the sample soon after collection will yield a gross alpha violation when there is no radium violation.

Current EPA regulations do not provide much guidance on how to proceed when one encounters a gross alpha violation. If the gross alpha activity is to be retained as a regulatory device, some plan of action should be set forth in the EPA regulations to try to identify the source of a gross alpha violation. If a sample with a gross alpha violation was processed soon after collection, the planchet could be recounted or the sample could be reanalyzed at a later time, when the Ra-224 activity has decayed away, in order to determine whether the gross alpha violation is related to the amount of Ra-224 in the sample. If the adjusted gross alpha was computed using a uranium activity determined using a gravimetric method, it could be recalculated using a uranium activity determined by a radiochemical method. Another step may be to determine whether a calculation of the gross alpha activity, based on the known activities of the most commonly measured radionuclides (U-234, U-235, U-238, Ra-226, and Ra-228) is consistent with the experimental gross alpha activity. If not, then it may be necessary to test the water for other radionuclides. In this study and others, the levels of thorium isotopes found in all of the water samples were not significant. In this study two samples had significant levels of Po-210. Consequently, when an unexplained gross alpha violation persists, a Po-210 determination may be in order. If the gross alpha violation persists, it may be necessary to test for radionuclides whose origin is due to human activity.

## Appendix A. Radiochemical Data.

This appendix has four tables containing the radiochemical data for each of the samples in this study. Each sample is characterized by a sample identification number (sample ID), a location, a public water system identification number (PWSID), and a well number. Only the sample identification number is used in the other three tables. Included with each data point is an error, based on a 95% confidence level, and a minimum detectable activity (MDA). All error estimates were determined using counting statistics only. Table 14 is a summary of the gross alpha and the gross beta activity data. Table 15 is a summary of the isotopic uranium data. Table 16 is a summary of the isotopic thorium data. There is no data for sample 78260. Table 17 is a summary of Ra-226, Ra-228, and Po-210 data. There are no Po-210 data for samples 78112, 78148, and 78325.

**Table 14. Gross alpha activity and gross beta activity data.**

Sample ID	Location	PWSID	Well no.	Gross Alpha			Gross Beta		
				Activity (pCi/L)	95% error (pCi/L)	MDA (pCi/L)	Activity (pCi/L)	95% error (pCi/L)	MDA (pCi/L)
78109	Lake Mills	128010850	6	11	2	2	6.2	1.4	2.2
78110	Johnson Creek	128010740	2	13	2	2	6	1.3	2.2
78111	Johnson Creek	128010740	3	22	3	1	12	2	2
78112	Lake Mills	128010850	5	14	2	2	8.3	1.6	2.5
78113	Lake Mills	128010850	4	13	2	1	5.9	1.5	2.6
78147	Hustiford Waterworks	114014890	2	19	3	2	12	2	2
78148	Hustiford Waterworks	114014890	3	40	4	2	20	2	3
78149	Reeseville Waterworks	114015330	1	5	2	2	4.4	1.3	2.3
78150	Reeseville Waterworks	114015330	2	22	3	2	9.5	1.6	2.6
78173	Pell Lake Sanitary District No. 1	265146970	1	64	4	1	29	2	2
78174	Country Estates Community Assoc.	265012770	4	15	2	1	9.9	1.1	1.4
78175	Union Grove Waterworks	252020010	4	30	3	1	15	1	2
78176	Union Grove Waterworks	252020010	5	23	3	1	14	1	2
78177	Southern Wisconsin Center	252019900	3	29	3	1	15	1	2
78178	Waterford Waterworks	252020230	2	34	3	1	19	1.4	1.5
78254	Winneconne Waterworks	471035400	1	48	3	1	16	1	1
78255	Winneconne Waterworks	471035400	2	30	3	1	12	1	1
78256	Berlin Waterworks	424021620	4	24	2	1	12	1	2
78257	Berlin Waterworks	424021620	5	20	2	1	9.6	1	1.5
78258	Berlin Waterworks	424021620	6	18	2	1	6.9	0.9	1.3
78259	Princeton Waterworks	424021950	1	33	2	1	12	1	1
78260	Princeton Waterworks	424021950	2	28	2	1	14	1	1
78319	Bellevue TN Sanitary District No. 1	405045960	1	39	4	3	25	1.4	1.7
78320	Bellevue TN Sanitary District No. 1	405045960	2	36	3	2	20.3	1.4	1.9
78321	Bellevue TN Sanitary District No. 1	405045960	3	66	4	2	29.5	1.4	1.7
78322	Bellevue TN Sanitary District No. 1	405045960	4	68	5	2	32.3	1.5	1.7
78323	Allouez Waterworks	405045520	1	21	3	2	16	1	2
78324	Allouez Waterworks	405045520	2	18	3	2	13	1	1
78325	Allouez Waterworks	405045520	5	13	2	1	12	1	1
78326	Allouez Waterworks	405045520	6	44	5	2	22.1	1.4	1.5

(Table 14 continued.)

Sample ID	Location	PWSID	Well no.	Gross alpha			Gross Beta		
				Activity (pCi/L)	95% error (pCi/L)	MDA (pCi/L)	Activity (pCi/L)	95% error (pCi/L)	MDA (pCi/L)
78327	Allouez Waterworks	405045520	7	51	4	2	20.5	1.3	1.4
79933	Waukesha Water Utility	268023800	9	19	3	2	28	2	2
79934	Waukesha Water Utility	268023800	8	11	2	2	17	2	2
79935	Waukesha Water Utility	268023800	7	9	2	2	9	2	3
79936	Waukesha Water Utility	268023800	6	13	3	2	25	2	2
79937	Waukesha Water Utility	268023800	5	12	2	2	16.8	1.6	2.2
79938	Waukesha Water Utility	268023800	10	26	4	2	16	2	2
79939	City of Pewaukee Water & Sewer Utility	268023800	1	17	2	2	14	1	1
79940	City of Pewaukee Water & Sewer Utility	268023800	2	22	3	2	11	2	2
79941	City of Pewaukee Water & Sewer Utility	268023800	5	12	3	2	8.1	1.5	2.4
79942	City of Pewaukee Water & Sewer Utility	268023800	6	11	3	2	10	2	2
80348	Squires Grove	268020170	2	53	5	2	19.1	1.6	2.3
80349	New Berlin Water Utility	268021710	1	26	3	2	14	1	2
80350	New Berlin Water Utility	268021710	3	27	3	2	13	1	2
80351	New Berlin Water Utility	268021710	4	20	3	2	9.9	1.4	2.3
80352	New Berlin Water Utility	268021710	7	42	4	2	17.6	1.6	2.3
80353	New Berlin Water Utility	268021710	8	49	4	3	46	2	2
80354	Brookfield Water Utility	268025340	6	1	2	3	2.5	1.5	2.8
80355	Brookfield Water Utility	268025340	15	27	5	3	12	2	3
80356	Brookfield Water Utility	268025340	22	18	4	3	10	2	3
80357	Brookfield Water Utility	268025340	29	28	5	3	15	2	3
80507	Menomonee Falls	268574900	7	45	6	2	14	1	2
80508	Mukwonago	268020940	3	19	3	1	8.2	1	1.3
80509	Muskego	260228100	2	34	4	1	16	1	2
80510	Eagle	268019840	1	35	4	1	14	1	2
80511	Menomonee Falls	268574900	3	96	7	2	30	2	2
80512	Mukwonago	268020940	4	34	2	1	14.6	0.9	0.9
80513	Eagle	268019840	2	29	2	1	12.9	0.9	0.9
80514	Hales Corners	268027650	1	55	4	2	18.1	1.1	1.2
80515	Menomonee Falls	268574900	5	75	5	2	22.3	1.2	1.3
80516	Hales Corners-Lake Lore	268021050		38	4	1	16	1	1
80730	Gresham Waterworks	459045400	1	11	3	3	9	2	3
80731	Gresham Waterworks	459045400	2	32	4	2	8	2	4
80732	Gresham Waterworks	459045400	3	183	8	2	52	2	2
80733	Kaukauna Electric and Water Dept.	445033600	4	78	7	3	24	2	2
80734	Kaukauna Electric and Water Dept.	445033600	5	53	6	4	20.5	1.6	2.1
80735	Kaukauna Electric and Water Dept.	445033600	10	37	4	2	16.2	1.6	2.4
80736	Shawano Municipal Utilities	459045620	2	78	7	2	13	2	4
80737	Shawano Municipal Utilities	459045620	3	62	6	2	11	2	3
80742	Thorp Waterworks	610033710	9	24.8	2.8	0.9	13.3	1.3	1.6
80743	Thorp Waterworks	610033710	12	143.8	6.8	1	19	1.4	1.3
84263	Ledgeview TN Sanitary Dist #2	405141880	1	22	4	2	13	2	2
84264	De Pere Water Department	405045300	1	16	4	3	12	2	3
84265	De Pere Water Department	405045300	4	31	5	2	16	2	2
84266	De Pere Water Department	405045300	2	24	5	3	17	2	2

(Table 14 continued.)

Sample ID	Location	PWSID	Well no.	Gross alpha			Gross beta		
				Activity (pC/L)	95% error (pCi/L)	MDA (pCi/L)	Activity (pC/L)	95% error (pCi/L)	MDA (pCi/L)
84267	De Pere Water Department	405045300	5	34	5	2	20	3	2
84268	Scott TN Sanitary Dist #1	405007130	1	34	3	2	20.5	1.5	1.5
84269	Darboy Sanitary Dist. #1	445011710	1	27	3	2	13	1	1
84270	Rustic Acres MHP	443049420	1	2	1	1.3	1.7	0.9	1.4
84271	Rustic Acres MHP	443049420	2	3	2	3	3	2	3
84272	Peshtigo Waterworks	438044200	2	14	3	2	12	2	2
84273	Peshtigo Waterworks	438044200	3	16	3	2	9	2	2
84521	Campbellsport Waterworks	420046110	3	36	3	2	17.4	1.5	1.5
84522	North Fond Du Lac Waterworks	420040500	3	4.2	1.5	1.8	3.8	1	1.4
84523	Mary Hill Park Sanitary Dist.	420046550	1	34	3	2	19.4	1.5	1.3
84524	Fond Du Lac Waterworks	420046990	11	28	3	2	13	1	2
84525	Fond Du Lac Waterworks	420046990	15	19	2	1	9.6	1.2	1.5
84526	Fond Du Lac Waterworks	420046990	17	42	4	2	18.8	1.5	1.3
84527	Fond Du Lac Waterworks	420046990	13	36	3	2	18.7	1.5	1.4
84528	Fond Du Lac Waterworks	420046990	19	38	4	2	18.2	1.5	1.5
84529	Fond Du Lac Waterworks	420046990	21	48	5	2	19	2	2
84530	North Fond Du Lac Waterworks	420040500	3	37	4	2	17	2	2
84669	Germantown Water Utility	267010590	3	37	4	3	18	2	2
84670	Sussex Village Hall & Water Utility	268023360	1	22	4	3	11	2	2
84671	Sussex Village Hall & Water Utility	268023360	2	25	4	1	15	2	2
84672	Sussex Village Hall & Water Utility	268023360	3	18	3	3	11	2	2
84675	Downsville Sanitary District	617026300	1	41	5	2	30	3	3
84677	Sussex Village Hall & Water Utility	268023360	4	17	4	3	14	2	2

Table 15. Uranium data.

Sample ID	U-234			U-235			U-238		
	Activity (pC/L)	95% error (pCi/L)	MDA (pCi/L)	Activity (pC/L)	95% error (pCi/L)	MDA (pCi/L)	Activity (pC/L)	95% error (pCi/L)	MDA (pCi/L)
78109	1.67	0.067	0.00036	0.01	0.009	0.00025	0.31	0.040	0.00023
78110	1.42	0.102	0.00031	0.02	0.012	0.00011	0.20	0.039	0.00042
78111	0.30	0.038	0.00019	0.01	0.005	0.000077	0.04	0.014	0.00021
78112	2.40	0.119	0.00015	0.01	0.008	0.00015	0.21	0.032	0.00015
78113	2.53	0.123	0.00036	0.02	0.011	0.00025	0.32	0.040	0.00023
78147	0.84	0.046	0.00035	0.01	0.005	0.00025	0.09	0.022	0.00030
78148	1.31	0.083	0.00036	0.01	0.007	0.00025	0.30	0.039	0.00022
78149	1.70	0.094	0.00022	0.01	0.007	0.000074	0.21	0.032	0.00029
78150	3.20	0.142	0.00036	0.02	0.011	0.00026	0.46	0.049	0.00023
78173	0.10	0.016	0.00035	0.00	0.003	0.00025	0.02	0.010	0.00022
78174	0.04	0.014	0.00022	0.00	0.003	0.000076	0.01	0.012	0.00030
78175	2.58	0.127	0.00020	0.02	0.010	0.000081	0.17	0.030	0.00022
78176	2.50	0.124	0.00015	0.01	0.007	0.00015	0.18	0.031	0.00015
78177	2.13	0.113	0.00038	0.01	0.010	0.00027	0.16	0.029	0.00024
78178	2.61	0.125	0.00019	0.01	0.006	0.000078	0.22	0.033	0.00021

(Table 15 continued.)

Sample ID	U-234			U-235			U-238		
	Activity (pCi/L)	95% error (pCi/L)	MDA (pCi/L)	Activity (pCi/L)	95% error (pCi/L)	MDA (pCi/L)	Activity (pCi/L)	95% error (pCi/L)	MDA (pCi/L)
78254	15.69	0.438	0.00014	0.09	0.021	0.00014	1.83	0.101	0.00014
78255	10.29	0.321	0.00037	0.07	0.020	0.00026	1.24	0.083	0.00023
78256	2.05	0.078	0.00023	0.02	0.010	0.000082	0.32	0.041	0.00031
78257	1.61	0.094	0.00014	0.02	0.009	0.00015	0.23	0.034	0.00015
78258	4.62	0.177	0.00035	0.04	0.014	0.00025	0.69	0.059	0.00022
78259	1.62	0.092	0.00019	0.01	0.007	0.000074	0.23	0.033	0.00020
78260	1.92	0.105	0.00019	0.02	0.009	0.000078	0.31	0.040	0.00021
78319	4.86	0.144	0.00049	0.03	0.014	0.00034	0.32	0.045	0.00015
78320	4.47	0.174	0.00022	0.02	0.010	0.000076	0.28	0.038	0.00030
78321	6.34	0.103	0.00011	0.03	0.004	0.000026	0.33	0.014	0.00013
78322	5.21	0.092	0.00014	0.03	0.004	0.000026	0.43	0.016	0.00020
78323	3.64	0.156	0.00020	0.01	0.008	0.000080	0.21	0.033	0.00022
78324	2.18	0.113	0.00015	0.02	0.009	0.00015	0.12	0.024	0.00015
78325	2.28	0.115	0.00036	0.01	0.008	0.00025	0.11	0.024	0.00022
78326	3.64	0.154	0.00019	0.01	0.008	0.000078	0.19	0.031	0.00021
78327	4.53	0.186	0.00021	0.02	0.011	0.000085	0.23	0.036	0.00023
79933	1.17	0.052	0.00010	0.02	0.004	0.00010	0.15	0.012	0.00010
79934	1.03	0.048	0.00030	0.01	0.004	0.00020	0.08	0.009	0.00017
79935	0.78	0.042	0.00014	0.01	0.002	0.000036	0.07	0.008	0.00016
79936	0.97	0.105	0.00033	0.02	0.015	0.000033	0.09	0.030	0.00033
79937	2.01	0.117	0.00018	0.02	0.010	0.00018	0.13	0.027	0.00018
79938	1.96	0.108	0.00040	0.01	0.010	0.00028	0.11	0.024	0.00025
79939	2.42	0.123	0.00022	0.01	0.009	0.000086	0.17	0.031	0.00024
79940	1.53	0.099	0.00024	0.01	0.006	0.000095	0.14	0.029	0.00026
79941	5.54	0.218	0.00045	0.04	0.017	0.00032	0.68	0.065	0.00028
79942	2.90	0.103	0.00025	0.02	0.007	0.000098	0.26	0.028	0.00027
80348	5.66	0.095	0.00012	0.02	0.003	0.000025	0.13	0.008	0.00014
80349	3.74	0.074	0.00076	0.02	0.003	0.000076	0.16	0.008	0.000076
80350	3.85	0.076	0.00026	0.02	0.003	0.00017	0.19	0.009	0.00015
80351	3.80	0.076	0.00012	0.02	0.003	0.000025	0.14	0.008	0.00014
80352	2.84	0.132	0.00015	0.02	0.010	0.00015	0.16	0.028	0.00015
80353	4.05	0.168	0.00040	0.03	0.014	0.00028	0.21	0.033	0.00025
80354	0.29	0.038	0.00021	0.01	0.007	0.000082	0.23	0.034	0.00023
80355	4.44	0.139	0.00013	0.02	0.006	0.00013	0.18	0.021	0.00013
80356	3.42	0.116	0.00034	0.01	0.007	0.00023	0.11	0.016	0.00021
80357	2.77	0.077	0.00020	0.01	0.004	0.000066	0.09	0.011	0.00022
80507	2.44	0.092	0.00022	0.02	0.007	0.019	0.08	0.016	0.00024
80508	0.62	0.061	0.00041	0.02	0.007	0.0054	0.04	0.017	0.00026
80509	3.58	0.088	0.00013	0.01	0.009	0.019	0.19	0.013	0.00015
80510	0.11	0.025	0.00017	0.02	0.004	0.0039	0.02	0.011	0.00017
80511	6.30	0.249	0.00042	0.02	0.010	0.016	0.21	0.037	0.00026
80512	1.77	0.108	0.00022	0.03	0.014	0.0085	0.09	0.025	0.00024
80513	0.13	0.028	0.00024	0.01	0.007	0.0047	0.00	-0.005	0.00026
80514	4.28	0.153	0.00036	0.02	0.006	0.016	0.19	0.027	0.00022
80515	6.17	0.194	0.00019	0.01	0.007	0.026	0.27	0.032	0.00021

(continued.)									
Sample ID	U-234			U-235			U-238		
	Activity (pCi/L)	95% error (pCi/L)	MDA (pCi/L)	Activity (pCi/L)	95% error (pCi/L)	MDA (pCi/L)	Activity (pCi/L)	95% error (pCi/L)	MDA (pCi/L)
80516	2.55	0.118	0.00022	0.01	0.006	0.0089	0.13	0.024	0.00024
80730	3.11	0.142	0.00016	0.08	0.020	0.00016	2.11	0.113	0.00016
80731	17.29	0.327	0.00035	0.26	0.017	0.00025	5.73	0.094	0.00023
80732	82.74	2.061	0.00025	1.12	0.086	0.00010	24.26	0.685	0.00028
80733	2.14	0.118	0.00017	0.00	0.006	0.00017	0.13	0.026	0.00017
80734	2.27	0.116	0.00039	0.01	0.011	0.00027	0.15	0.028	0.00024
80735	1.65	0.097	0.00021	0.01	0.007	0.000082	0.12	0.025	0.00023
80736	63.11	1.591	0.00025	0.73	0.068	0.000099	16.23	0.489	0.00027
80737	42.70	0.370	0.000089	0.53	0.021	0.000089	10.69	0.099	0.000089
80742	2.04	0.066	0.00014	0.03	0.005	0.000035	0.62	0.023	0.00015
80743	78.21	0.612	0.00015	1.15	0.032	0.000037	25.32	0.176	0.00017
84263	2.36	0.127	0.00040	0.03	0.013	0.00028	0.20	0.033	0.00028
84264	2.07	0.118	0.00040	0.02	0.012	0.00022	0.12	0.026	0.00029
84265	3.13	0.153	0.00027	0.01	0.009	0.00020	0.20	0.033	0.00025
84266	2.97	0.143	0.00039	0.01	0.009	0.00021	0.19	0.032	0.00029
84267	3.21	0.153	0.00040	0.03	0.014	0.00028	0.20	0.034	0.00028
84268	2.85	0.154	0.00031	0.03	0.013	0.00018	0.22	0.036	0.00031
84269	1.22	0.086	0.00039	0.02	0.010	0.00021	0.12	0.026	0.00029
84270	0.17	0.032	0.00041	0.00	0.006	0.00028	0.05	0.017	0.00028
84271	0.07	0.022	0.00032	0.00	0.004	0.00023	0.02	0.014	0.00029
84272	0.22	0.038	0.00037	0.01	0.008	0.00027	0.03	0.014	0.00024
84273	0.60	0.062	0.00043	0.01	0.008	0.00024	0.04	0.017	0.00032
84521	7.50	0.267	0.00023	0.02	0.011	0.00019	0.30	0.040	0.00025
84522	0.20	0.033	0.00032	0.01	0.007	0.000084	0.06	0.018	0.00029
84523	0.73	0.064	0.00021	0.00	0.005	0.00015	0.05	0.017	0.00022
84524	2.76	0.138	0.00043	0.03	0.013	0.00027	0.27	0.039	0.00035
84525	1.22	0.090	0.00024	0.02	0.010	0.00017	0.15	0.030	0.00025
84526	7.67	0.270	0.00023	0.02	0.011	0.00019	0.51	0.052	0.00024
84527	3.09	0.146	0.00041	0.02	0.011	0.00026	0.24	0.036	0.00034
84528	5.64	0.220	0.00021	0.03	0.012	0.00015	0.58	0.057	0.00022
84529	3.88	0.170	0.00024	0.01	0.009	0.00019	0.38	0.045	0.00025
84530	2.20	0.123	0.00034	0.12	0.025	0.00091	0.37	0.046	0.00032
84669	2.16	0.121	0.00022	0.04	0.015	0.00015	0.11	0.025	0.00023
84670	2.32	0.124	0.00033	0.01	0.008	0.000087	0.13	0.027	0.00030
84671	3.24	0.152	0.00042	0.06	0.019	0.00027	0.29	0.040	0.00035
84672	1.05	0.077	0.00021	0.01	0.006	0.00015	0.07	0.019	0.00035
84675	0.50	0.055	0.00026	0.06	0.018	0.00021	0.12	0.026	0.00027
84677	2.98	0.147	0.00044	0.12	0.026	0.00028	0.34	0.045	0.00036

**Table 16. Thorium data.**

Sample ID	Th-228			Th-230			Th-232		
	Activity (pCi/L)	95% error (pCi/L)	MDA (pCi/L)	Activity (pCi/L)	95% error (pCi/L)	MDA (pCi/L)	Activity (pCi/L)	95% error (pCi/L)	MDA (pCi/L)
78109	0.0154	0.0109	0.00019	0.0155	0.0072	0.00011	0.0027	0.0031	0.000093
78110	-0.0039	0.0116	0.00041	0.0300	0.0147	0.00037	0.0033	0.0053	0.00020
78111	0.0082	0.0115	0.00014	0.0251	0.0097	0.00013	0.0000	0.0029	0.00015
78112	0.0128	0.0106	0.00021	0.0118	0.0066	0.00012	0.0038	0.0038	0.00010
78113	-0.0040	0.0498	0.00014	0.0193	0.0063	0.00013	0.0011	0.0024	0.000093
78147	-0.0022	0.0063	0.00014	0.0200	0.0055	0.00075	0.0027	0.0022	0.000059
78148	-0.0084	0.0061	0.000067	0.0191	0.0048	0.000060	0.0022	0.0024	0.000078
78149	0.0092	0.0046	0.000087	0.0087	0.0037	0.000087	-0.0030	0.0023	0.00012
78150	-0.0037	0.0050	0.00012	0.0123	0.0040	0.000063	0.0022	0.0018	0.000050
78173	-0.0047	0.0056	0.00015	0.0157	0.0045	0.000076	0.0011	0.0017	0.000059
78174	-0.0250	0.0245	0.0019	0.0310	0.0251	0.0016	0.0100	0.0121	0.00078
78175	0.0011	0.0070	0.00022	0.0252	0.0074	0.00011	0.0044	0.0033	0.000089
78176	0.0005	0.0093	0.00032	0.0103	0.0087	0.00028	0.0030	0.0040	0.00014
78177	0.0445	0.0103	0.00017	0.0133	0.0049	0.000091	0.0040	0.0028	0.000072
78178	0.0071	0.0066	0.00015	0.0425	0.0102	0.00013	0.0016	0.0045	0.00017
78254	-0.0011	0.0052	0.00013	0.0160	0.0064	0.00013	-0.0024	0.0037	0.00018
78255	-0.0012	0.0049	0.00016	0.0208	0.0084	0.00014	0.0008	0.0043	0.00018
78256	-0.0165	0.0558	0.00012	0.0120	0.0046	0.00011	0.0003	0.0019	0.000076
78257	0.0013	0.0039	0.000095	0.0101	0.0041	0.000095	-0.0010	0.0031	0.00013
78258	0.0016	0.0053	0.00017	0.0099	0.0059	0.00015	0.0011	0.0048	0.00019
78259	0.0183	0.0651	0.00020	0.0172	0.0065	0.00017	-0.0026	0.0029	0.00014
78260	—	—	—	—	—	—	—	—	—
78319	0.1393	0.0197	0.00011	0.0303	0.0029	0.00010	0.0039	0.0015	0.00011
78320	0.0962	0.0170	0.00012	0.0108	0.0020	0.00011	-0.0005	-0.0006	0.000074
78321	0.1427	0.0296	0.00025	0.0150	0.0080	0.00023	-0.0037	0.0059	0.00025
78322	0.2211	0.0320	0.00014	0.0233	0.0066	0.00014	0.0005	0.0034	0.00013
78323	0.0967	0.0284	0.00053	0.0210	0.0141	0.00044	-0.0053	0.0090	0.00036
78324	0.0150	0.0183	0.00038	0.0244	0.0066	0.00034	0.0117	0.0037	0.00016
78325	0.0780	0.0182	0.00020	0.0162	0.0063	0.00017	0.0000	0.0036	0.00014
78326	0.1286	0.0252	0.00018	0.0152	0.0068	0.00018	0.0015	0.0045	0.00017
78327	0.0307	0.0201	0.00019	0.0347	0.0044	0.000097	0.0078	0.0021	0.000076
79933	0.0154	0.0457	0.00042	0.2036	0.0293	0.00042	0.0082	0.0113	0.00039
79934	0.0142	0.0304	0.00046	0.2444	0.0296	0.00039	0.0070	0.0093	0.00032
79935	0.0053	0.0260	0.00042	0.1210	0.0246	0.00038	-0.0016	0.0105	0.00042
79936	0.1063	0.0399	0.00035	1.3546	0.0933	0.00032	0.0212	0.0090	0.00022
79937	0.0746	0.0558	0.00086	0.1316	0.0427	0.00086	0.0012	0.0199	0.00080
79938	0.0017	0.0291	0.00037	0.9995	0.0744	0.00031	0.0080	0.0078	0.00026
79939	0.0018	0.0198	0.00026	0.1605	0.0242	0.00024	0.0041	0.0072	0.00026
79940	0.0176	0.0213	0.00030	0.4424	0.0459	0.00027	0.0095	0.0069	0.00019
79941	-0.0002	0.0127	0.00036	0.5375	0.0413	0.00033	0.0140	0.0071	0.00036
79942	0.0232	0.0261	0.00053	0.4803	0.0662	0.00053	0.0136	0.0149	0.00050
80348	0.0086	0.0275	0.00023	0.0700	0.0138	0.00021	0.0108	0.0076	0.00023
80349	0.0187	0.0258	0.00025	0.0589	0.0149	0.00023	0.0092	0.0081	0.00025
80350	0.0036	0.0262	0.00038	0.0692	0.0166	0.00032	0.0043	0.0074	0.00026



(Table 16 continued.)

Sample ID	Th-228			Th-230			Th-232		
	Activity (pCi/L)	95% error (pCi/L)	MDA (pCi/L)	Activity (pCi/L)	95% error (pCi/L)	MDA (pCi/L)	Activity (pCi/L)	95% error (pCi/L)	MDA (pCi/L)
80351	-0.0201	0.1918	0.00022	0.0733	0.0789	0.00020	0.0164	0.0186	0.00014
80352	0.0367	0.0291	0.00023	0.0688	0.0153	0.00021	0.0091	0.0075	0.00023
80353	0.0585	0.0674	0.00037	0.0694	0.0165	0.00031	0.0062	0.0077	0.00026
80354	-0.0055	0.0158	0.00036	0.0991	0.0236	0.00033	-0.0016	0.0085	0.00036
80355	0.0254	0.0249	0.00024	0.0640	0.0151	0.00022	0.0047	0.0069	0.00024
80356	0.0127	0.0340	0.00072	0.0676	0.0253	0.00061	0.0099	0.0145	0.00050
80357	0.0028	0.0252	0.00025	0.0756	0.0168	0.00023	0.0049	0.0072	0.00025
80507	-0.0063	0.0881	0.00023	0.0743	0.0473	0.00021	0.0005	0.0061	0.00023
80508	-0.0355	0.0339	0.00028	0.0573	0.0263	0.00024	0.0080	0.0056	0.00020
80509	-0.0448	0.0799	0.00021	0.0609	0.0388	0.00019	0.0107	0.0082	0.00013
80510	-0.0675	0.0627	0.00049	0.0501	0.0567	0.00041	0.0116	0.0164	0.00034
80511	-0.0236	0.4068	0.00025	0.0677	0.0734	0.00023	0.0097	0.0131	0.00025
80512	-0.0493	0.1403	0.00029	0.0858	0.0926	0.00027	0.0175	0.0204	0.00019
80513	-0.0497	0.0783	0.00078	0.0787	0.0764	0.00066	0.0069	0.0164	0.00054
80514	0.0264	0.1452	0.00020	0.0695	0.0625	0.00019	0.0074	0.0091	0.00020
80515	-0.1144	0.3631	0.0017	0.0632	0.0512	0.0016	0.0074	0.0273	0.00011
80516	-0.1146	0.3810	0.00025	0.0923	0.0178	0.00023	0.0074	0.0057	0.00016
80730	0.0704	0.0293	0.00024	0.0561	0.0128	0.00022	0.0144	0.0066	0.00015
80731	0.0079	0.1023	0.00046	0.0800	0.0200	0.00039	0.0110	0.0101	0.00032
80732	0.1453	0.0262	0.00023	0.0721	0.0139	0.00021	0.0146	0.0064	0.00014
80733	0.0944	0.1725	0.00033	0.0646	0.0179	0.00030	0.0081	0.0097	0.00033
80734	0.0125	0.0357	0.00034	0.0565	0.0143	0.00029	0.0108	0.0079	0.00024
80735	0.1716	0.1327	0.00033	0.0585	0.0167	0.00031	0.0035	0.0059	0.00021
80736	-0.1119	0.1142	0.00030	0.0715	0.0134	0.00025	0.0136	0.0072	0.00021
80737	0.3002	0.1339	0.00022	0.5089	0.0443	0.00020	0.0536	0.0109	0.00014
80742	-0.0380	0.0293	0.00024	0.0584	0.0139	0.00022	0.0131	0.0067	0.00016
80743	0.1048	0.1019	0.00020	0.4895	0.0433	0.00019	0.0457	0.0109	0.00020
84263	0.0112	0.0108	0.00027	0.0463	0.0125	0.00021	0.0078	0.0055	0.00015
84264	0.0037	0.0099	0.00031	0.0407	0.0116	0.00021	0.0001	0.0043	0.00019
84265	0.0045	0.0130	0.00039	0.0316	0.0120	0.00030	0.0061	0.0049	0.00014
84266	0.0181	0.0136	0.00027	0.0361	0.0113	0.00021	0.0052	0.0049	0.00015
84267	-0.0380	0.0509	0.0021	0.0248	0.0445	0.00016	-0.0127	0.0189	0.0011
84268	0.0039	0.0145	0.00039	0.0265	0.0111	0.00025	-0.0031	0.0044	0.00023
84269	0.0020	0.0135	0.00040	0.0364	0.0126	0.00030	0.0088	0.0056	0.00014
84270	0.0082	0.0113	0.00033	0.0640	0.0166	0.00026	0.0072	0.0063	0.00019
84271	0.0104	0.0162	0.00054	0.0582	0.0188	0.00035	-0.0043	0.0061	0.00032
84272	0.0634	0.0157	0.00025	0.0411	0.0107	0.00020	0.0045	0.0044	0.00014
84273	0.0040	0.0127	0.00036	0.0368	0.0113	0.00023	0.0029	0.0057	0.00021
84521	0.0616	0.0359	0.00036	0.1449	0.0237	0.00029	0.0294	0.0105	0.00021
84522	0.0064	0.0083	0.00028	0.0459	0.0115	0.00014	0.0082	0.0054	0.00014
84523	0.0011	0.0169	0.00039	0.0255	0.0127	0.00037	0.0011	0.0068	0.00026
84524	0.0149	0.0161	0.00036	0.0647	0.0149	0.00021	0.0047	0.0055	0.00019
84525	0.1840	0.0291	0.00034	0.0548	0.0144	0.00028	0.0047	0.0061	0.00021
84526	-0.0002	0.0151	0.00033	0.0347	0.0122	0.00031	0.0010	0.0059	0.00023
84527	-0.1359	0.0519	0.00013	0.0946	0.0449	0.00012	0.0146	0.0249	0.00088

(Table 16 continued.)

Sample ID	Th-228			Th-230			Th-232		
	Activity (pCi/L)	95% error (pCi/L)	MDA (pCi/L)	Activity (pCi/L)	95% error (pCi/L)	MDA (pCi/L)	Activity (pCi/L)	95% error (pCi/L)	MDA (pCi/L)
84528	0.0201	0.0384	0.00026	0.0409	0.0104	0.00013	0.0029	0.0037	0.00013
84529	0.0096	0.0176	0.00036	0.0310	0.0126	0.00034	0.0029	0.0067	0.00024
84530	0.0255	0.0173	0.00029	0.0336	0.0107	0.00023	0.0034	0.0050	0.00017
84669	0.0127	0.0152	0.00031	0.0284	0.0093	0.00018	0.0046	0.0049	0.00016
84670	0.0063	0.0153	0.00039	0.0557	0.0156	0.00036	0.0043	0.0073	0.00026
84671	0.0244	0.0146	0.00031	0.0882	0.0170	0.00015	0.0179	0.0077	0.00015
84672	0.1546	0.0269	0.00028	0.0543	0.0124	0.00013	0.0087	0.0054	0.00013
84675	0.0219	0.0214	0.00031	0.0675	0.0141	0.00018	0.0125	0.0066	0.00016
84677	0.1014	0.0224	0.00033	0.0279	0.0115	0.00031	0.0026	0.0061	0.00022

**Table 17. Po-210, Ra-226, and Ra-228 data.**

Sample ID	Po-210			Ra-226			Ra-228		
	Activity (pCi/L)	95% error (pCi/L)	MDA (pCi/L)	Activity (pCi/L)	95% error (pCi/L)	MDA (pCi/L)	Activity (pCi/L)	95% error (pCi/L)	MDA (pCi/L)
78109	0.0305	0.0395	0.0072	1.87	0.15	0.03	2.1	0.6	0.7
78110	0.1372	0.0378	0.0032	2.08	0.15	0.03	1.5	0.5	0.6
78111	0.0280	0.0391	0.0069	4.5	0.2	0.1	3.6	0.7	0.8
78112	—	—	—	3.0	0.2	0.1	1.8	0.6	0.7
78113	0.1637	0.0224	0.0020	1.2	0.1	0.1	1.1	0.5	0.8
78147	-0.0089	0.0060	0.0016	3.7	0.2	0.1	3.8	0.7	0.8
78148	—	—	—	7.1	0.2	0.1	6.7	0.9	0.7
78149	0.0160	0.0060	0.0098	0.92	0.10	0.06	0.5	0.5	0.8
78150	0.0214	0.0061	0.0087	4.4	0.2	0.1	2.5	0.7	0.9
78173	0.0068	0.0111	0.0016	13.5	0.4	0.1	7.7	0.9	0.7
78174	0.0036	0.0103	0.00056	3.0	0.2	0.1	1.8	0.6	0.8
78175	0.0062	0.0096	0.00055	5.8	0.2	0.1	3.2	0.9	1.1
78176	0.0241	0.0110	0.0015	3.7	0.2	0.1	2.1	0.7	0.9
78177	0.0108	0.0107	0.0015	3.9	0.2	0.1	3.1	0.8	0.9
78178	0.0042	0.0156	0.0019	7.1	0.2	0.1	3.1	0.8	1.0
78254	0.0164	0.0073	0.0011	5.5	0.2	0.1	4.3	0.9	1.0
78255	0.0304	0.0064	0.0014	2.34	0.15	0.06	2.1	0.8	1.0
78256	0.1070	0.0118	0.00076	2.9	0.2	0.1	3.1	0.8	0.9
78257	0.0743	0.0079	0.00069	2.29	0.16	0.04	2.5	0.8	1.1
78258	0.0174	0.0120	0.0013	2.80	0.16	0.04	1.4	0.7	1.0
78259	0.0174	0.0120	0.0013	5.1	0.2	0.1	4.1	0.9	1.0
78260	0.0143	0.0081	0.0013	5.6	0.2	0.1	3.8	0.9	1.1
78319	0.0111	0.0122	0.0022	8.6	0.3	0.1	6.0	1.0	0.8
78320	0.1021	0.0223	0.0042	7.4	0.3	0.1	4.9	0.9	0.8
78321	0.0228	0.0206	0.0030	15.2	0.4	0.1	5.3	1.1	1.0
78322	0.0111	0.0124	0.0029	17.0	0.4	0.1	9.0	1.2	1.0
78323	0.1590	0.0192	0.0029	5.1	0.2	0.1	3.4	0.8	0.9
78324	0.2081	0.0167	0.0011	3.7	0.2	0.1	3.1	0.8	1.0
78325	—	—	—	2.3	0.2	0.1	2.2	0.9	1.2
78326	0.1611	0.0177	0.0010	9.2	0.3	0.1	4.6	1.0	1.1

(Table 17 continued.)

sample ID	Po-210			Ra-226			Ra-228		
	Activity (pCi/L)	95% error (pCi/L)	MDA (pCi/L)	Activity (pCi/L)	95% error (pCi/L)	MDA (pCi/L)	Activity (pCi/L)	95% error (pCi/L)	MDA (pCi/L)
78327	0.1456	0.0123	0.0016	9.3	0.3	0.1	4.5	1.2	1.4
79933	0.2218	0.0186	0.0015	4.9	0.3	0.1	18.1	1.6	1.1
79934	0.0209	0.0162	0.0013	3.2	0.2	0.1	10	1	1
79935	0.0229	0.0160	0.00091	2.8	0.2	0.1	4.5	1.0	1.1
79936	0.0372	0.0159	0.0027	3.6	0.2	0.1	16	1	1
79937	0.0349	0.0233	0.0046	3.2	0.2	0.1	8.4	1.1	0.9
79938	0.0351	0.0114	0.0023	5.7	0.3	0.1	8.4	1.2	1.1
79939	0.0340	0.0164	0.0025	2.3	0.2	0.1	3.8	0.8	1.0
79940	0.0398	0.0150	0.0024	5.4	0.3	0.1	3.4	0.8	1.0
79941	0.0610	0.0166	0.0025	1.93	0.16	0.06	1.5	0.8	1.2
79942	0.0448	0.0168	0.0010	2.8	0.2	0.1	2.5	0.7	0.8
80348	0.0068	0.0106	0.0029	8.5	0.3	0.1	5.0	0.7	0.5
80349	0.0031	0.0142	0.00087	4.2	0.2	0.1	3.3	0.6	0.6
80350	0.0097	0.0163	0.0016	4.0	0.2	0.1	3.8	0.6	0.6
80351	0.0037	0.0151	0.0021	3.5	0.2	0.1	3.7	0.7	0.7
80352	0.0087	0.0152	0.0022	3.8	0.2	0.1	3.8	0.7	0.7
80353	0.0090	0.0252	0.0023	5.4	0.3	0.1	19.8	1.2	0.6
80354	0.0990	0.0167	0.0014	0.39	0.09	0.08	0.7	0.4	0.6
80355	0.0106	0.0170	0.0026	4.5	0.2	0.1	2.8	0.6	0.6
80356	0.0102	0.0169	0.0026	3.0	0.2	0.1	2.9	0.6	0.6
80357	0.0144	0.0316	0.0035	1.85	0.15	0.05	2.8	0.7	0.8
80507	0.0068	0.0116	0.0030	2.9	0.2	0.1	4.2	0.7	0.6
80508	0.0282	0.0140	0.0019	3.7	0.2	0.1	3.0	0.7	0.8
80509	0.0044	0.0159	0.00093	5.6	0.2	0.1	4.9	0.8	0.8
80510	0.0072	0.0145	0.00080	5.2	0.2	0.1	3.5	0.8	1
80511	0.0080	0.0224	0.0015	5.4	0.2	0.1	12	1	1
80512	0.0103	0.0138	0.0010	5.8	0.2	0.1	5.3	0.8	0.7
80513	0.0052	0.0147	0.0020	5.89	0.27	0.06	3.73	0.84	0.91
80514	0.0066	0.0144	0.0013	6.28	0.28	0.09	3.99	0.75	0.75
80515	0.0099	0.0196	0.0016	6.74	0.29	0.06	8.59	1.00	0.78
80516	0.0055	0.0162	0.0014	4.20	0.27	0.15	3.86	1.07	2.45
80730	0.1518	0.0190	0.0028	0.65	0.11	0.05	0.95	0.63	0.93
80731	0.1657	0.0099	0.0023	0.64	0.10	0.06	1.15	0.57	0.81
80732	6.1809	0.4229	0.0018	0.59	0.11	0.10	0.21	0.44	0.71
80733	0.0287	0.0325	0.0092	3.26	0.21	0.06	4.58	0.86	0.94
80734	0.0052	0.0250	0.0043	2.96	0.2	0.05	3.37	0.74	0.86
80735	0.0068	0.0154	0.00095	3.06	0.22	0.12	2.71	0.72	0.84
80736	0.3744	0.0236	0.0011	1.12	0.14	0.10	1.26	0.73	1.03
80737	0.0499	0.0147	0.0011	0.94	0.13	0.08	0.56	0.84	1.33
80742	0.0784	0.0151	0.0025	0.89	0.12	0.06	2.19	0.66	0.8
80743	4.5960	0.2578	0.00098	3.54	0.23	0.10	1.43	0.64	0.87
84263	0.0167	0.0474	0.0098	2.9	0.2	0.1	1.8	0.6	0.6
84264	0.0332	0.0518	0.0074	1.65	0.15	0.1	0.9	0.5	0.7
84265	0.0038	0.0476	0.0080	3.8	0.2	0.1	2.2	0.6	0.6
84266	0.0846	0.0482	0.010	3.8	0.2	0.1	3.6	0.8	0.8

(Table 17 continued.)

sample ID	Po-210			Ra-226			Ra-228		
	Activity (pC/L)	95% error (pCi/L)	MDA (pCi/L)	Activity (pC/L)	95% error (pCi/L)	MDA (pCi/L)	Activity (pC/L)	95% error (pCi/L)	MDA (pCi/L)
84267	0.0191	0.0449	0.0055	4.8	0.3	0.1	5	0.8	0.7
84268	0.0110	0.0506	0.0070	5.2	0.2	0.1	2.9	0.7	0.7
84269	0.0055	0.0467	0.0078	3.6	0.2	0.1	2.4	0.6	0.7
84270	0.0054	0.0493	0.011	0.76	0.11	0.09	0.3	0.6	0.9
84271	0.0105	0.0466	0.0059	0.17	0.06	0.06	-0.1	0.5	0.9
84272	0.1883	0.0488	0.0081	3.2	0.2	0.1	1.4	0.6	0.8
84273	0.0084	0.0479	0.010	3.6	0.3	0.2	1.6	0.7	0.9
84521	-0.0014	0.0500	0.0074	5.2	0.2	0.1	3	0.6	0.6
84522	0.0165	0.0508	0.0076	0.42	0.08	0.07	-0.1	0.4	0.7
84523	0.0043	0.0464	0.0073	5.2	0.2	0.1	5	0.8	0.6
84524	0.1065	0.0481	0.0067	5.8	0.2	0.1	2.6	0.7	0.9
84525	0.0106	0.0526	0.0093	3	0.2	0.1	1	0.6	0.9
84526	0.0039	0.0464	0.0052	6.2	0.2	0.1	3.6	0.8	0.8
84527	0.0258	0.0471	0.0044	5.2	0.2	0.1	4.9	0.8	0.8
84528	0.0228	0.0494	0.0071	9.5	0.4	0.1	3.5	0.8	0.7
84529	0.0136	0.0456	0.0051	7.6	0.3	0.1	4.8	0.8	0.7
84530	0.0326	0.0479	0.0045	6.1	0.2	0.1	3.6	0.9	0.9
84669	0.0166	0.0516	0.0064	5.6	0.3	0.1	4.6	0.5	0.4
84670	0.0000	0.0495	0.0072	3.4	0.2	0.1	3.5	0.5	0.5
84671	0.0156	0.0513	0.0052	4.5	0.2	0.1	2.5	0.4	0.5
84672	0.0085	0.0488	0.0070	4.2	0.2	0.1	1.7	0.6	0.7
84675	0.0367	0.0468	0.0074	10.6	0.4	0.1	6.1	0.8	0.6
84677	0.0044	0.0491	0.0058	2.6	0.2	0.1	2.6	0.5	0.5

## Appendix B. Gross Alpha Calculations.

This table in this appendix gives a summary of some of the data from Appendix A and gives the results of the gross alpha calculations. The first entry is the sample identification number. The second entry is the solid film weight in the planchet. The third entry is the time between sample collection and sample preparation. The fourth entry is the time between sample preparation and sample analysis. The fifth entry is the gross alpha activity of the sample measured in the laboratory. The sixth entry is the calculated gross alpha activity, assuming that Ra-224 is in secular equilibrium with Ra-228, i.e., assuming that the activity of Ra-224 equals the activity of Ra-228. The seventh entry is the value of the Ra-224 activity required to make the calculated gross alpha activity equal the measured gross alpha activity. The eighth entry of the table is the measured Ra-228 activity. The last entry of the table is the ratio of the calculated Ra-224 activity to the measured Ra-228 activity

**Table 18.** Results of gross alpha simulations for water samples.

Sample ID	Solid film weight (mg)	Time between sample coll. and prep. (days)	Time between sample prep. and anal. (days)	Gross alpha activity (pCi/L)	Calculated gross alpha activity (pCi/L)	Calculated Value of Ra-224 activity (pCi/L)	Ra-228 activity (pCi/L)	Ratio of Ra-224 to Ra-228
78109	19.4	0.96	1.40	11	12.78	1.59	2.1	0.75
78110	19.9	1.02	1.40	13	10.74	2.16	1.5	1.44
78111	18.4	1.04	1.40	22	20.94	3.91	3.6	1.09
78112	20.1	0.94	1.40	14	14.65	1.61	1.8	0.90
78113	20.8	0.95	1.40	13	9.03	2.23	1.1	2.03
78147	26.9	1.13	0.59	19	20.90	3.30	3.8	0.87
78148	20.7	1.12	0.59	40	35.74	7.89	6.7	1.18
78149	20.5	1.08	0.59	5	5.04	0.49	0.5	0.98
78150	17.8	1.09	0.59	22	18.62	3.47	2.5	1.39
78173	26.7	1.06	0.20	64	44.69	12.90	7.7	1.68
78174	29.6	1.06	0.20	15	10.53	2.97	1.8	1.65
78175	32.4	0.97	0.20	30	22.65	5.03	3.2	1.57
78176	34.0	0.96	0.20	23	15.83	3.85	2.1	1.84
78177	62.9	0.94	0.20	29	22.65	4.38	3.1	1.41
78178	61.6	0.92	0.20	34	27.19	4.47	3.1	1.44
78254	34.3	1.02	0.33	48	42.90	5.53	4.3	1.29
78255	34.6	1.04	0.33	30	23.52	3.66	2.1	1.74
78256	27.6	0.94	0.33	24	18.22	4.58	3.1	1.48
78257	31.8	0.93	0.33	20	15.12	3.69	2.5	1.47
78258	23.9	0.96	0.33	18	14.13	2.43	1.4	1.74
78259	24.7	0.89	0.33	33	24.05	6.44	4.1	1.57
78260	25.9	0.89	0.33	28	24.14	4.79	3.8	1.26
78319	55.5	30.08	3.17	39	33.85	—	6	—
78320	48.7	30.06	3.17	36	28.90	—	4.9	—

(Table 18 continued)

Sample ID	Solid film weight (mg)	Time between sample coll. and prep. (days)	Time between sample prep. and anal. (days)	Gross alpha activity (pCi/L)	Calculated gross alpha activity (pCi/L)	Calculated value of Ra-224 activity (pCi/L)	Ra-228 activity (pCi/L)	Ratio of Ra-224 to Ra-228
78321	51.3	30.07	3.17	66	56.55	—	5.3	—
78322	67.7	30.04	3.17	68	63.29	—	9	—
78323	91.1	29.94	2.50	21	19.05	—	3.4	—
78324	81.0	29.97	2.94	18	14.48	—	3.1	—
78325	50.3	29.91	2.94	13	9.73	—	2.2	—
78326	88.2	29.99	2.94	44	33.64	—	4.6	—
78327	70.1	30.01	2.94	51	35.30	—	4.5	—
79933	66.6	64.81	2.46	19	15.83	—	18.1	—
79934	48.4	64.12	2.60	11	10.48	—	10	—
79935	33.3	64.09	2.70	9	8.59	—	4.5	—
79936	47.3	64.10	2.84	13	12.02	—	16	—
79937	71.8	64.14	3.01	12	12.77	—	8.4	—
79938	51.7	64.16	3.15	26	20.69	—	8.4	—
79939	56.9	59.07	11.41	17	15.47	—	3.8	—
79940	47.2	64.05	3.40	22	19.64	—	3.4	—
79941	62.4	64.02	3.53	12	13.20	—	1.5	—
79942	59.2	64.04	3.67	11	13.30	—	2.5	—
80348	42.4	1.04	2.40	53	48.11	6.30	5	1.26
80349	41.2	0.91	1.31	26	27.49	2.97	3.3	0.90
80350	44.0	0.90	1.31	27	30.02	3.14	3.8	0.83
80351	36.2	0.92	1.31	20	26.90	2.08	3.7	0.56
80352	43.5	0.95	1.31	42	28.24	6.83	3.8	1.80
80353	68.9	34.93	4.50	49	26.23	—	19.8	—
80354	49.0	1.13	2.24	1	4.32	-0.13	0.7	-0.19
80355	52.8	1.11	2.24	27	28.73	2.38	2.8	0.85
80356	42.0	1.09	2.24	18	22.66	1.67	2.9	0.58
80357	52.3	1.07	2.24	28	19.63	4.83	2.8	1.73
80507	80.9	1.16	0.25	45	26.81	7.95	4.2	1.89
80508	38.7	0.92	0.25	19	18.42	3.13	3	1.04
80509	46.8	1.08	0.25	34	33.21	5.07	4.9	1.04
80510	35.4	0.88	0.25	35	21.50	6.67	3.5	1.91
80511	67.7	2.13	0.34	96	63.76	19.82	12	1.65
80512	38.8	0.93	0.53	34	34.43	5.20	5.3	0.98
80513	33.3	0.90	0.53	29	24.70	4.73	3.73	1.27
80514	77.6	1.00	0.53	55	35.37	7.73	3.99	1.94
80515	87.7	1.14	0.53	75	59.91	11.62	8.59	1.35
80516	78.6	1.03	0.53	38	29.42	5.51	3.86	1.43
80730	28.9	1.06	1.05	11	9.66	1.29	0.95	1.36
80731	15.5	1.08	1.05	32	27.39	2.53	1.15	2.20
80732	44.7	1.07	0.40	183	115.08	15.08	0.21	71.82
80733	85.6	0.91	0.40	78	30.67	13.74	4.58	3.00
80734	88.1	0.92	0.40	53	23.93	9.06	3.37	2.69
80735	52.2	0.93	0.40	37	19.54	6.24	2.71	2.30

(Table 18 continued)

sample ID	Solid film weight (mg)	Time between sample coll. and prep. (days)	Time between sample prep. and anal. (days)	Gross alpha activity (pCi/L)	Calculated gross alpha activity (pCi/L)	Calculated Value of Ra-224 activity (pCi/L)	Ra-228 activity (pCi/L)	Ratio of Ra-224 to Ra-228
80736	13.2	1.01	1.05	78	84.32	-0.65	1.26	-0.52
80737	13.5	1.02	1.05	62	56.13	2.33	0.56	4.17
80742	31.8	1.03	0.05	24.8	11.91	5.57	2.19	2.54
80743	33.0	1.03	0.05	143.8	115.87	8.65	1.43	6.05
84263	33.9	1.98	0.24	22	12.33	4.65	1.8	2.59
84264	25.6	1.89	0.24	16	7.09	3.72	0.9	4.14
84265	38.0	1.92	0.24	31	16.08	6.37	2.2	2.90
84266	33.3	1.90	0.24	24	20.29	4.68	3.6	1.30
84267	28.3	1.93	0.24	34	25.47	7.65	5	1.53
84268	59.9	2.04	0.43	34	22.79	5.59	2.9	1.93
84269	71.6	1.85	0.43	27	17.23	4.61	2.4	1.92
84270	13.7	2.10	0.43	2	2.01	0.29	0.3	0.98
84271	15.4	2.08	0.25	3	0.02	0.99	-0.1	-9.95
84272	17.1	2.16	0.25	14	7.89	3.64	1.4	2.60
84273	18.0	2.18	0.25	16	9.35	4.02	1.6	2.51
84521	47.9	1.90	1.39	36	31.07	4.27	3	1.42
84522	36.6	2.08	1.39	4.2	0.78	0.91	-0.1	-9.06
84523	42.4	1.94	1.39	34	30.24	6.02	5	1.20
84524	48.9	2.05	1.39	28	25.56	3.24	2.6	1.25
84525	42.3	2.02	1.39	19	11.37	3.10	1	3.10
84526	54.5	1.98	1.39	42	36.48	4.98	3.6	1.38
84527	51.3	2.04	1.39	36	33.73	5.49	4.9	1.12
84528	61.2	2.00	1.07	38	40.01	3.02	3.5	0.86
84529	53.3	2.01	1.07	48	38.77	7.07	4.8	1.47
84530	26.0	2.09	1.07	37	24.52	7.62	3.6	2.12
84669	32.2	3.10	4.24	37	28.82	9.65	4.6	2.10
84670	30.9	3.05	4.24	22	19.62	4.97	3.5	1.42
84671	34.6	3.05	4.24	25	23.35	3.48	2.5	1.39
84672	30.8	3.03	4.35	18	18.13	1.62	1.7	0.95
84675	36.3	9.96	5.61	41	44.65	-4.18	6.1	-0.68
84677	79.1	10.19	5.95	17	16.29	4.43	2.6	1.70

## References.

- 
- <sup>1</sup> *The Federal Register*, Vol. 65, No. 236, December 7, 2000.
- <sup>2</sup> Krieger and E. L. Whittaker, *Prescribed Procedures for Measurement of Radioactivity in Drinking Water*, United States Environmental Protection Agency, Environmental Monitoring and Support Laboratory, EPA-6000/4-80-032, August 1980., p. 1-9.
- <sup>3</sup> *Ibid.* p. 10-14.
- <sup>4</sup> Kigoshi, K., *Science* **173**, 47-48 (1971).
- <sup>5</sup> Gilkeson, R. H., and E. C., Cowart, *Radium, Radon, and Uranium isotopes in ground water from Cambrian-Ordovician Sandstone Aquifers in Illinois in Radon in Ground Water-Hydrogeologic Impact and Indoor Air Contamination*, p. 402, Graves, Barbara, ed., Chelsea Mich., Lewis Publishers Inc. (1987).
- <sup>6</sup> A. I. Bushev, V. G. Tiptsova, and V. M. Ivanov, *Handbook of the Analytical Chemistry of the Rare Elements*, p. 82, Ann Arbor-Humphrey Science Publishers, Ann Arbor (1970).
- <sup>7</sup> Buschbeck, E. C., *Gmelin Handbook of Inorganic and Organometallic Chemistry*, Polonium Supplement Vol. 1, 8<sup>th</sup> Edition, Springer-Verlag, Berlin (1990).
- <sup>8</sup> I. C. Yang, *Sampling and Analysis of Dissolved Radon-222 in Surface Water and Ground Water in Radon in Ground Water in Radon in Ground Water-Hydrogeologic Impact and Indoor Air Contamination*, p. 193-203, Graves, Barbara, ed., Chelsea Mich., Lewis Publishers Inc. (1987).
- <sup>9</sup> Half-life data taken from Weast, R. C., *CRC Handbook of Chemistry and Physics*, 57<sup>th</sup> Edition, CRC Press, Boca Raton, Florida (1976).
- <sup>10</sup> Hess, C.T., Michel, J., Horton T. R., Prichard, H. M., and Coniglio, W. A., *Health Physics* **48**, 553-586 (1985).
- <sup>11</sup> Focazia, F.J., Szabo, Z., Kraemer, T.G., Mullin, A.H., Barringer, T.H., and dePaul, V.T., *Occurrence of Selected Radionuclides in Ground Water Used for Drinking Water in the United States: A Reconnaissance Survey*, 1998, U.S. Geological Survey, Water-Resources Investigations Report 00-4273.
- <sup>12</sup> Krieger and E. L. Whittaker, *Prescribed Procedures for Measurement of Radioactivity in Drinking Water*, United States Environmental Protection Agency, Environmental Monitoring and Support Laboratory, EPA-6000/4-80-032, August 1980, p. 38-48.
- <sup>13</sup> *Ibid.* p. 49-57.
- <sup>14</sup> *Method Po-02, Polonium in Water Vegetation, Soil, and Air Filters*, Environmental Measurements Laboratory Procedures Manual, 27 ed., vol. 1, Environmental Measurements Laboratory, U.S. Department of Energy, 376 Hudson St., New York, NY 100014-3621 (1990).



- 
- <sup>15</sup> H. Iwaski, K. Kanichi, and T. Tarutani, *Journal of Chromatography*, 429-434 (1980).
- <sup>16</sup> R. K. Iler, *The Colloid Chemistry of Silica and Silicates*, Cornell University Press, New York (1955).
- <sup>17</sup> *Uranium in Water*, Method ACW02, Rev. 1.3, Eichrom Technologies, Inc., Darien IL (2001).
- <sup>18</sup> *Thorium in Water*, Method ACW10, Rev. 1.0, Eichrom Technologies, Inc., Darien IL (2001).
- <sup>19</sup> W. Stumm and J. J. Morgan, *Aquatic Chemistry: An Introduction Emphasizing Chemical Equilibria in Natural Waters*, 2<sup>nd</sup> Ed. p. 551, John Wiley and Sons, New York (1981).
- <sup>20</sup> Data take from Weast, R. C., *CRC Handbook of Chemistry and Physics*, 57<sup>th</sup> Edition, CRC Press, Boca Raton, Florida (1976).
- <sup>21</sup> The National Institute of Standards and Technology ASTAR program can be accessed at the web site: <http://physics.nist.gov/PhysRefData/Star/Text/ASTAR.html>
- <sup>22</sup> Krieger and E. L. Whittaker, *Prescribed Procedures for Measurement of Radioactivity in Drinking Water*, United States Environmental Protection Agency, Environmental Monitoring and Support Laboratory, EPA-6000/4-80-032, August 1980., p. 96-102.
- <sup>23</sup> *ibid.* p. 103-109.